

深圳市阿美林电子科技有限公司

7 寸 TFT 模组规格书

SPECIFICATION

承 认 印 Approved by	
审核:	确认:

客户确认结果:

Customer

客 户: _____

Product

品 名: _____ 7 寸 TFT 模组

Part NO.

产品料号: _____ FRD70050LY35

DATE

日 期: _____

Approved 核 准	Checked 审 核	Prepared 制 作

1.0 General Description

1.1 Introduction

FRD70050LY35 Display model is a color active matrix thin film transistor (TFT) liquid crystal display (LCD) that uses amorphous silicon TFT as a switching device. This model is composed of a TFT LCD panel and a driving circuit. This TFT LCD has a 7.0 (16:9) inch diagonally measured active display area with (800 horizontal by 480 vertical pixels) resolution.

1.2. Features

7 (16:9 diagonal) inch configuration
Compatible with NTSC & PAL system
Image Reversion: UP/DOWN and LEFT/RIGHT
ROHS design

1.3. General information

Item	Specification	Unit
Outline Dimension	164.9 (H) x 100 (V) x 3.5 (D)	mm
Display area	154.08 (H) x 85.92 (V)	mm
Number of Pixel	800 RGB (H) x 480 (V)	pixels
Pixel pitch	0.0642 (H) x 0.1790 (V)s	mm
Pixel arrangement	RGB Vertical stripe	
Display mode	Normally white	
Color Filter Array	RGB vertical stripes	
Backlight	White LED	
Weight	TBD	g

2.0 Absolute Maximum Ratings

2.1 Electrical Absolute Rating

2.1.1 TFT LCD Module

Item	Symbol	Min.	Max.	Unit	Note
Power supply voltage	DV _{DD}	-0.3	5.0	V	GND=0
	AV _{DD}	-0.5	13.5	V	AGND=0
	V _{COM}	-	-	V	
Analog Signal Input Level	V _R , V _G , V _B	-0.2	AV _{DD} +0.2	V	
Logic Signal Input Level	V _I	-0.3	DV _{DD} +0.3	V	

Note (1) Stresses above those listed under "Absolute Maximum Rating" may cause permanent damage to the device. These are stress ratings only. Functional operation of this device at indicated in the operational sections(6.1) of this specification.

2.2 Environment Absolute Rating

Item	Symbol	Min.	Max.	Unit	Note
Operating Temperature	Topa	-10	60	°C	
Storage Temperature	Tstg	-20	70	°C	

2.3 Back-light Unit:

PARAMETER	Sym.	Min.	Typ.	Max.	Unit	Test Condition	Note
LED Current	I _F	-	120	-	mA	-	-
LED Voltage	V _F	9	9.9	10.5	V	-	-
Life Time		-	25000	-	Hr.	I ≤ 120mA	-
Color	White						

Note (1) Permanent damage may occur to the LCD module if beyond this specification. Functional operation should be restricted to the conditions described under normal operating conditions.

(2) Ta=25±2°C

(3) Test condition: LED Current 120mA

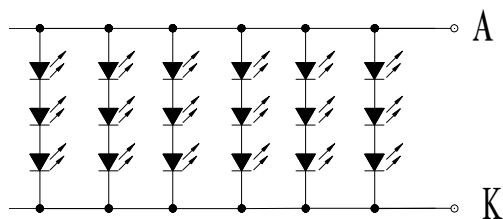

LED电路图

3.0 Optical Characteristics

3.1 Optical specification

Item	Symbol	Condition	Min.	Typ.	Max.	Unit	Note
Threshold voltage	V _{sat}		—	2.48	—	V	(1)
	V _{th}		—	1.47	—	V	(1)
Luminous intensity			180	230		cd/m ²	
Transmittance(With PZ)	T		—	8.91	—		
Contrast	CR		400	500	—		(2)(3)
Response time	Rising	T _R	—	5	7	msec	(2)(4)
	Falling	T _F	—	20	28		
Color gamut	S		—	49	—	%	C light
Color chromaticity (CIE1931)	White	W _x	θ=0 Normal viewing angle	0.26	0.31	0.36	(2)(5) CF Glass C light
		W _y		0.28	0.33	0.38	
	Red	R _x		0.616	0.631	0.646	
		R _y		0.327	0.342	0.357	
	Green	G _x		0.306	0.321	0.336	
		G _y		0.538	0.553	0.568	
	Blue	B _x		0.133	0.148	0.163	
		B _y		0.173	0.188	0.203	
Viewing angle	Hor.	θ _L	CR>10	60	70	—	
		θ _R		60	70	—	
	Ver.	θ _U		40	50	—	
		θ _D		60	70	—	
Brightness uniformity	B _{UNI}	θ=0	70	—	—	%	(6)
Optima View Direction			6 O' clock				(7)

3.2 Measuring Condition

- Measuring surrounding : dark room
- Ambient temperature : 25±2℃
- 30min. warm-up time.

3.3 Measuring Equipment

- TOPCON BM-7
- Measuring spot size : field 2°

Note (1) Definition of V_{sat} and V_{th} (at 20°C)

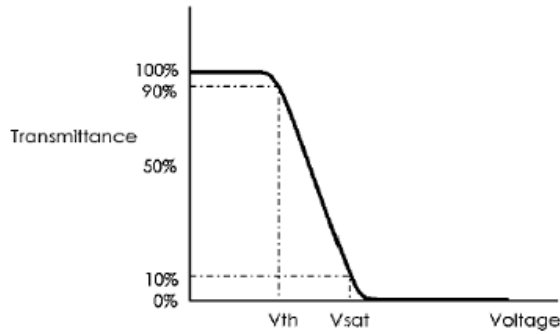

Note (2) Definition of Viewing Angle :

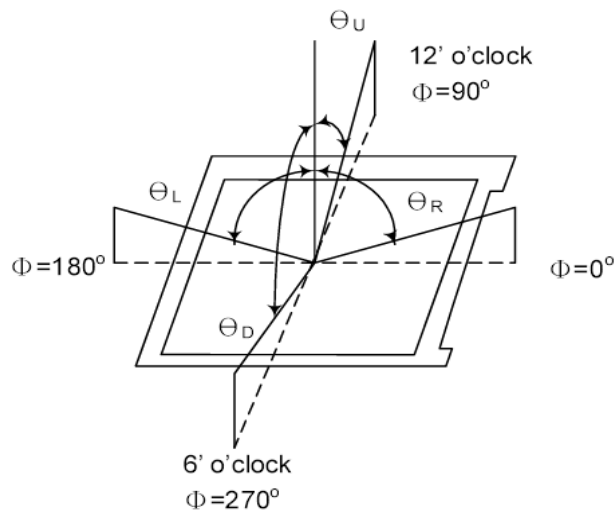

Note (3) Definition of Contrast Ratio(CR) :

measured at the center point of panel

$$CR = \frac{\text{Luminance with all pixels white}}{\text{Luminance with all pixels black}}$$

Note (4) Definition of Response Time : Sum of T_R and T_F

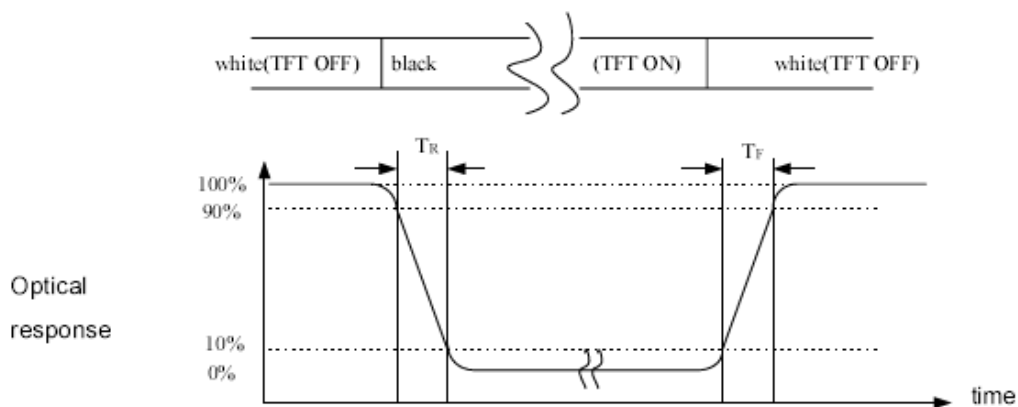

Note (5) Definition of optical measurement setup

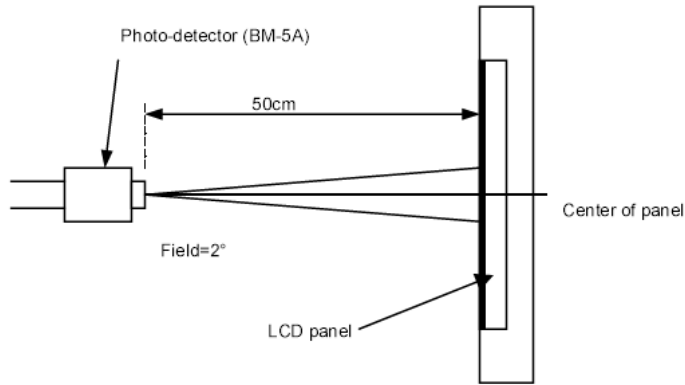

Note (6) Definition of brightness uniformity

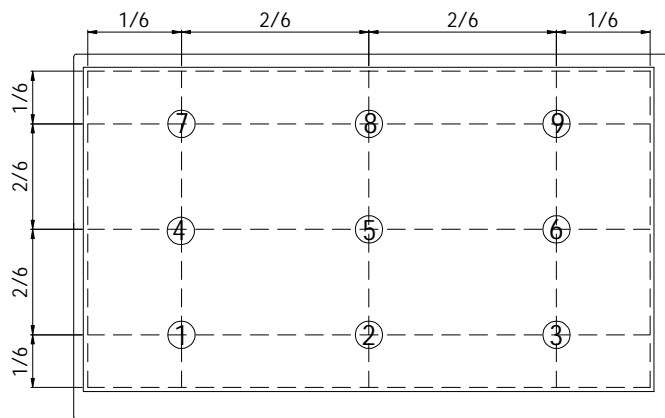

Note (7) Rubbing Direction (The different Rubbing Direction will cause the different optima view direction.)

4.0 Block Diagram

4.1 TFT-LCD Module

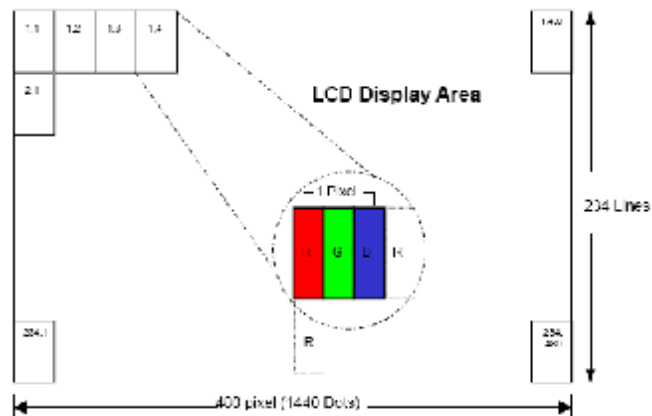

5.0 Interface Pin Connection

5.1 TFT LCD Module

<i>Pin.No</i>	<i>Symbol</i>	<i>Function</i>
1,2	VLED+	Power for LED backlight (Anode)
3,4	VLED-	Power for LED backlight (Cathode)
5	GND	Power ground
6	VCOM	Common Voltage
7	DVDD	Digital Power
8	MODE	DE/SYNC mode select. Normally pull high H: DE mode. L: HSD/VSD mode
9:	DE	Data Enable signal.
10	VSD	Vertical sync input. Negative polarity
11	HSD	Horizontal sync input. Negative polarity
12-19	B7-R0	Blue Data
20-27	G7-G0	Green Data
28-35	R7-R0	Red Data
36	GND	Ground
37	DCLK	Colock signal
38	GND	Display on/off
39	SHLR	Left or Right Display Control
40	UPDN	Up / Down Display Control
41	VDDG	Positive Power for TFT
42	VEEG	Negative Power for TFT
43	AVDD	Analog Power
44	RSTB	Global reset pin. Active low to enter reset state. Suggest to connecting with an RC reset circuit for stability. Normally pull high. (R=10K Ω , C=1 μ F)
45	NC	Not connect
46	VCOM	Common Voltage
47	DITH	Dithering setting DITH= " H " 6bit resolution(last 2 bit of input data truncated) DITH= " L " 8bit resolution(default setting)
48	GND	Power ground
49	NC	Not connect
50	NC	Not connect

Note 4: Selection of scanning mode

Setting of scan control input		Scanning direction
U/D	L/R	
GND	DV _{DD}	Up to down, left to right
DV _{DD}	GND	Down to up, right to left
GND	GND	Up to down, right to left
DV _{DD}	DV _{DD}	Down to up, left to right

Note 5: Definition of scanning direction.
Refer to the figure as below:

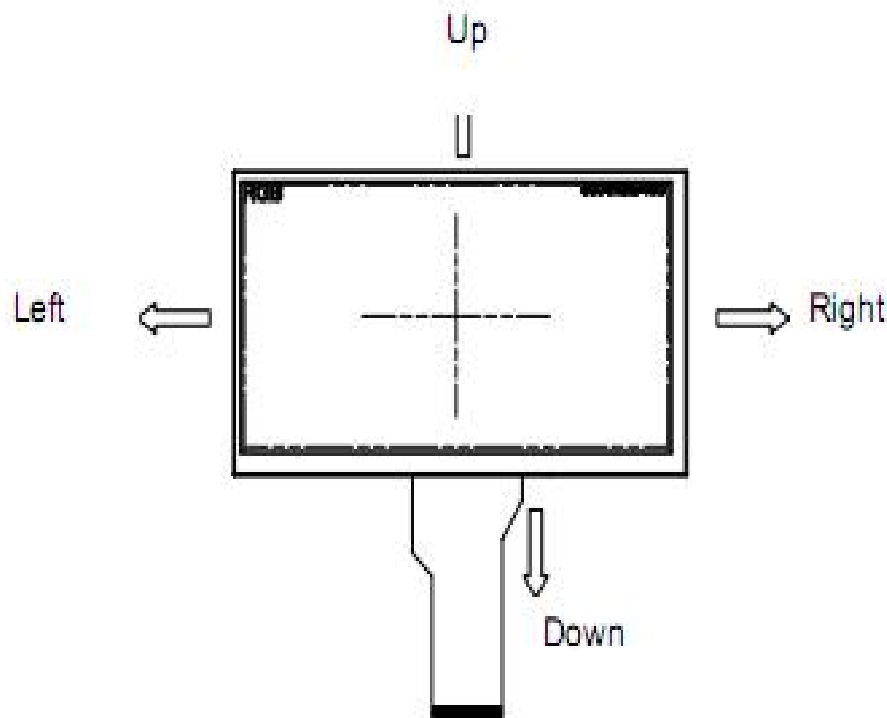

Note 6: Global reset pin. Active low to enter reset state. Suggest to connect with an RC reset circuit for stability. Normally pull high.

Note 7: Dithering function enable control, normally pull high.
When DITHB="1", Disable internal dithering function,
When DITHB="0", Enable internal dithering function,

Note 8: Reserve for LED power input.

深圳市阿美林电子科技有限公司

Note(1) Selection of scanning mode (please refer to the following table)

Setting of scan control input		IN/OUT state for start pulse				Scanning direction
U/D	L/R	STVD	STVU	STHR	STHL	
GND	DV _{DD}	Output	input	output	input	up to down, and from left to right
DV _{DD}	GND	input	output	input	output	down to up, and from right to left
GND	GND	output	input	input	output	up to down, and from right to left
DV _{DD}	DV _{DD}	input	output	output	input	down to up, and from left to right

Note(2) MOD=H: Simultaneous sampling.(Please check CPH2 and CPH3 to GND when MOD=H)

MOD=L: Sequential sampling.

6. Electrical Characteristics

6.1 TFT LCD Module

Item	Symbol	Min.	Typ.	Max.	Unit	Note
Supply Voltage	DV _{DD}	3.0	3.3	3.6	V	
	V _{GH}	15.3	16.0	16.7	V	
	V _{GL}	-7.7	-7.0	-6.3	V	
	AV _{DD}	10.2	10.4	10.6	V	
Video signal amplitude (VR,VG,VB)	V _{IA}	-	-	AV _{DD} -0.4	V	
	V _{IAC}	-	-	-	V	AC component,
	V _{IDC}	-	AV _{DD} /2	-	V	DC component
VCOM	V _{CAC}		-	-	VP-P	AC component
	V _{CDC}	-	-	-	V	DC component, (1)
Input signal voltage	V _{IH}	0.7DV _{DD}	-	DV _{DD}	V	(2)
	V _{IL}	0	-	0.3DV _{DD}	V	(2)
Current of power supply	I _{DD}	-	-		mA	DV _{DD} =3.3V
	I _{ADD}	-	-		mA	AV _{DD} =5V
	I _{GH}	-	-		uA	V _{GH} =15V
	I _{GL}	-	-		mA	V _{GL} =-10V

Note (1): The brightness of LCD panel could be changed by adjusting the AC component of VCOM.

Note (2): STHL, STHR, OEH, L/R, CPH1~CPH3, STVD, STVU, OEV, CKV, U/D

6.2 AC Characteristics

Item	Symbol	Values			Unit	Remark
		Min.	Typ.	Max.		
HS setup time	T_{Hst}	8	-	-	ns	
HS hold time	T_{Hhd}	8	-	-	ns	
VS setup time	T_{Vst}	8	-	-	ns	
VS hold time	T_{Vhd}	8	-	-	ns	
Data setup time	T_{dsu}	8	-	-	ns	
Data hole time	T_{dhd}	8	-	-	ns	
DE setup time	T_{esu}	8	-	-	ns	
DE hole time	T_{ehd}	8	-	-	ns	
DV _{DD} Power On Slew rate	T_{POR}	-	-	20	ms	From 0 to 90% DV _{DD}
RESET pulse width	T_{Rst}	1	-	-	ms	
DCLK cycle time	T_{cch}	20	-	-	ns	
DCLK pulse duty	T_{owh}	40	50	60	%	

6.3 Timing Diagram of Interface Signal

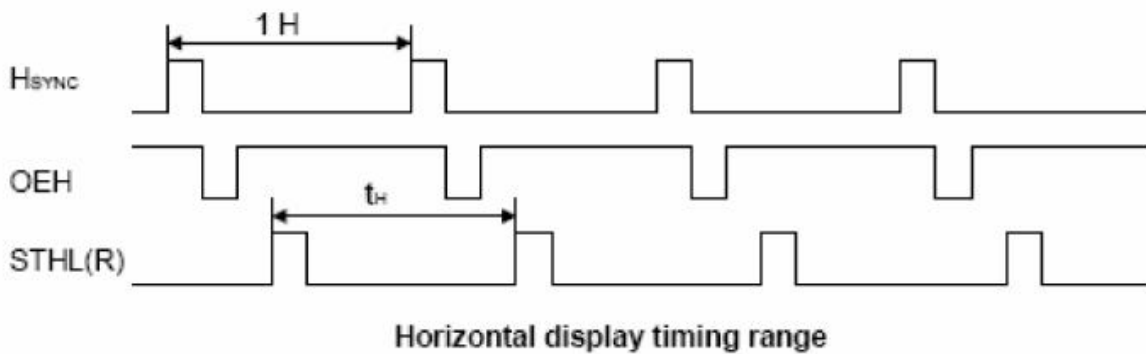
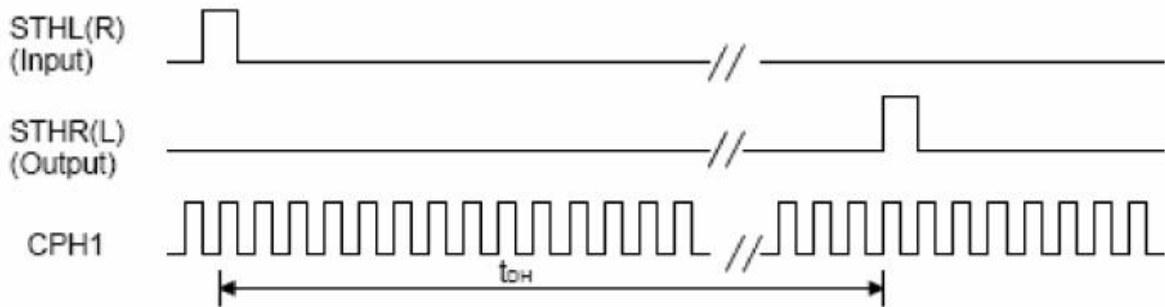
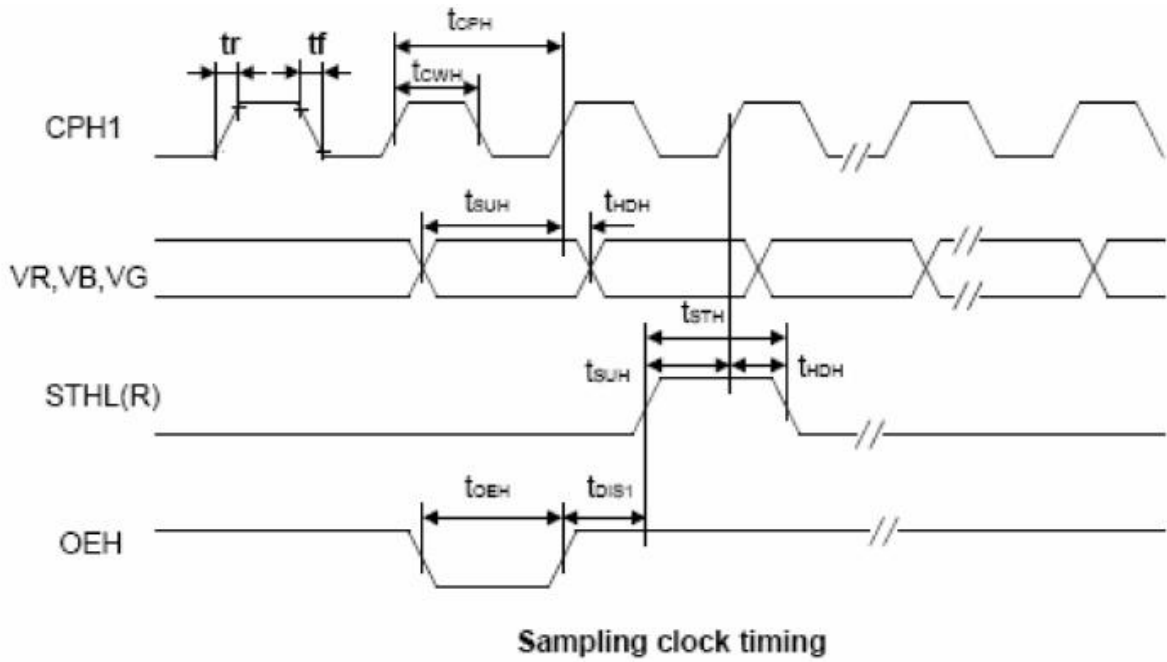

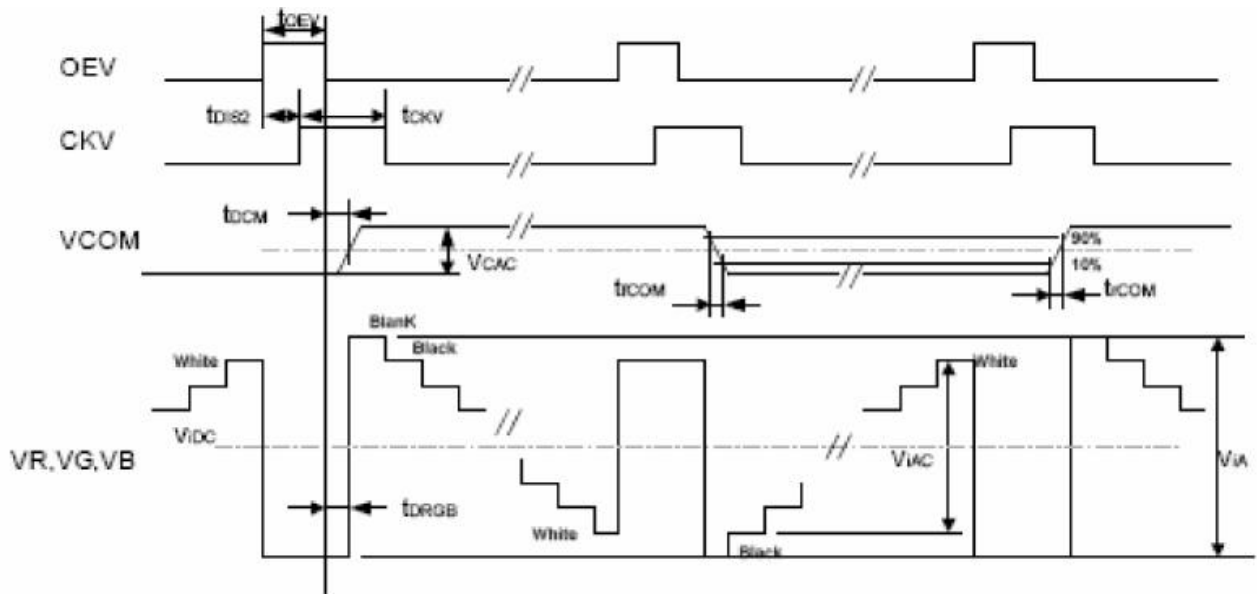

Detail Horizontal timing

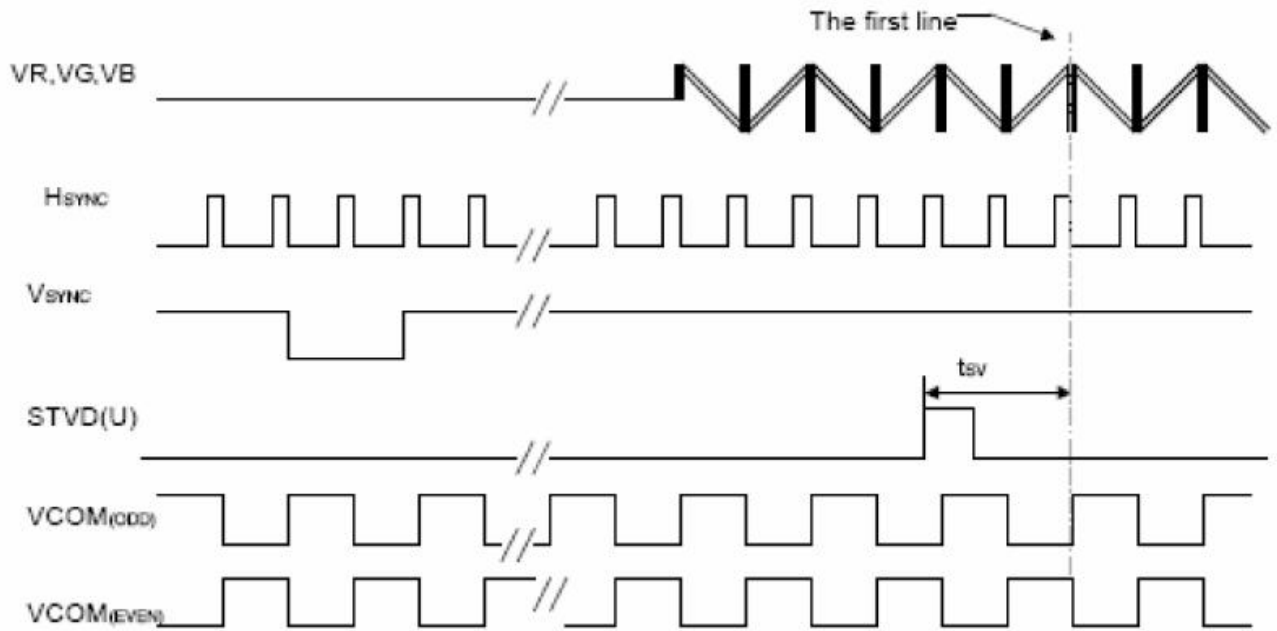

Vertical timing

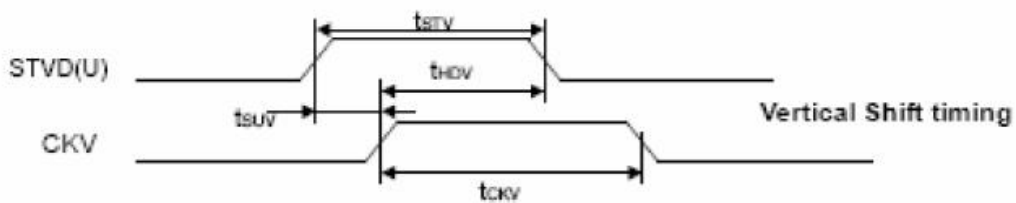

Vertical Shift timing

深圳市阿美林电子科技有限公司

Item	Symbol	Values			Unit	Remark
		Min.	Typ.	Max.		
Horizontal Display Area	thd	-	800	-	DCLK	
DCLK Frequency	fclk	26.4	33.3	46.8	MHz	
One Horizontal Line	th	862	1056	1200	DCLK	
HS pulse width	thpw	1	-	40	DCLK	
HS Blanking	thb	46	46	46	DCLK	
HS Front Porch	thfp	16	210	354	DCLK	

Item	Symbol	Values			Unit	Remark
		Min.	Typ.	Max.		
Vertical Display Area	tvd	-	480	-	TH	
VS period time	tv	510	525	650	TH	
VS pulse width	tvpw	1	-	20	TH	
VS Blanking	tvb	23	23	23	TH	
VS Front Porch	tvfp	7	22	147	TH	

6.4 Power Sequence

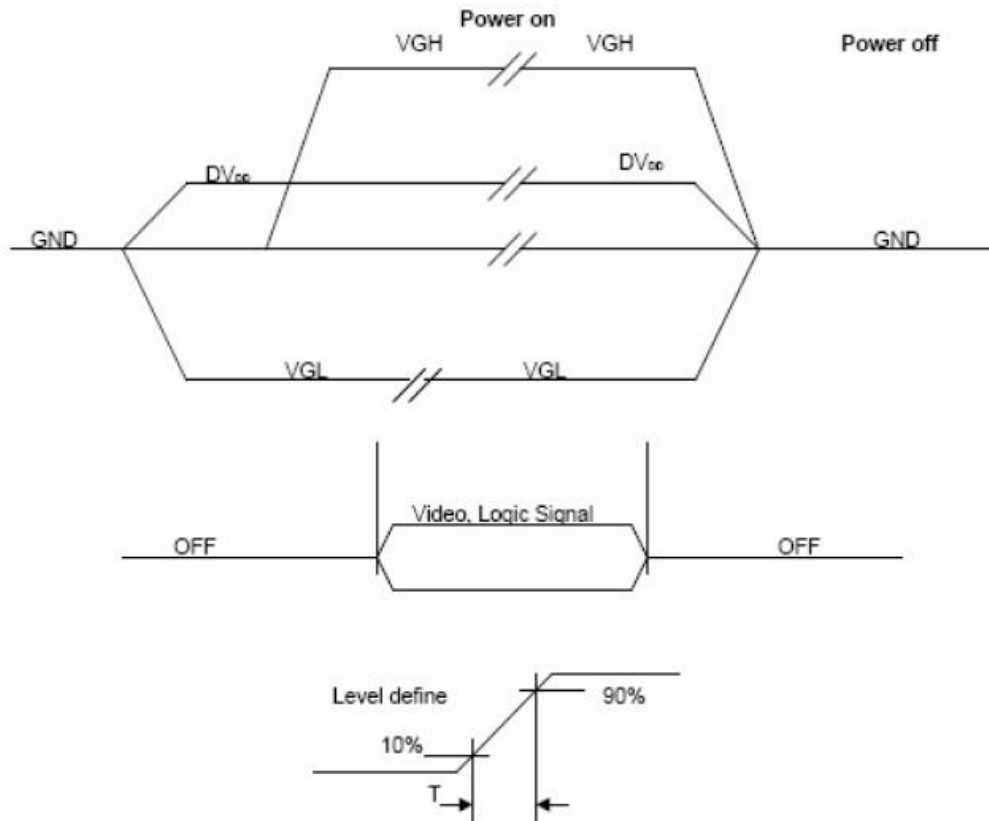

Power Sequence: DVDD -> VGL -> VGH

Note Apply the LED voltage within the LCD operation range. When the back-light turns on before the LCD operation or the LCD turns off before the back-light turns off, the display may momentarily become white.

7.0 Reliability test items

NO	Item	Conditions	Remark
1	High Temperature Storage	Ta=+70°C,240hrs	
2	Low Temperature Storage	Ta=-20°C,240hrs	
3	High Temperature Operation	Ta=+60°C,240hrs	
4	Low Temperature Operation	Ta=-10°C,240hrs	
5	High Temperature and High Humidity (operation)	Ta=+60°C,90%RH,240hrs	
6	Thermal Cycling Test (non operation)	-20°C(0.5hr)→+70°C(0.5hr),200cycles	
7	Vibration	1.Random:1.04G,10-500HZ,X,Y,Zdirection 30min/each direction 2.Sweep sine:1.5G, 5~500Hz, X/Y/Z,30min/each direction	
8	Shock	100G,6ms, ±X, ±Y, ±Z 3 time for each direction	JIS C7021, A-10 (Condition A)
9	Vibration (with carton)	Random:1.04Grms, 10~500Hz, X/Y/Z 45min/each direction Fixed:5Hz, 1.5Grms, X/Y/Z 45min/each direction	
10	Drop (with carton)	Height: 60cm 1 corner, 3 edges, 6 surfaces	JIS Z0202
11	Electrostatic Discharge	±200V,200PF,0Q1 time/each terminal	

Note: All tests above are practiced at module type.

There is no display function NG issue occurred, All the cosmetic specification is judged before the reliability stress.

8.0 Outline dimension

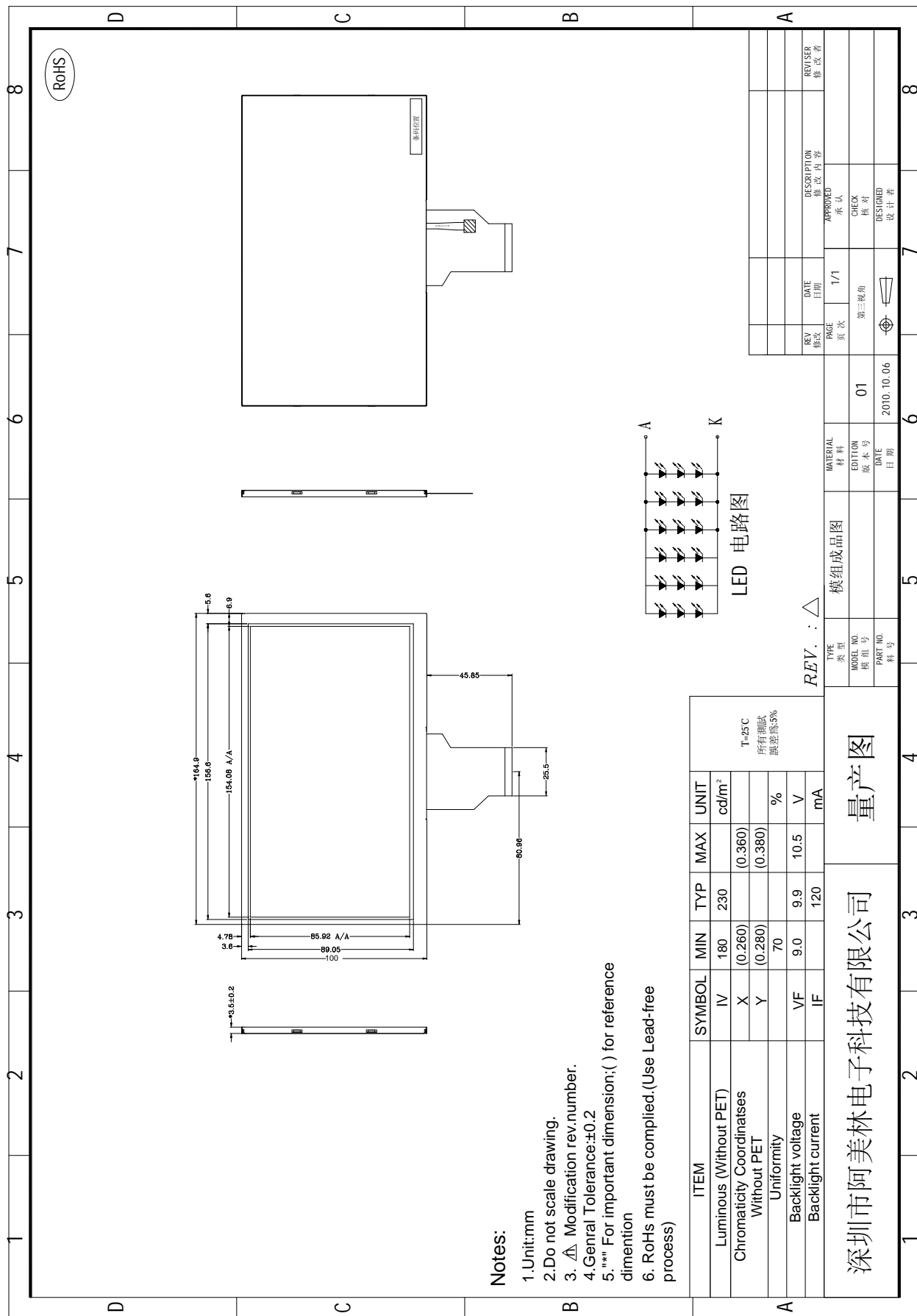

9.0 Packing form

9.1 Packing form 1

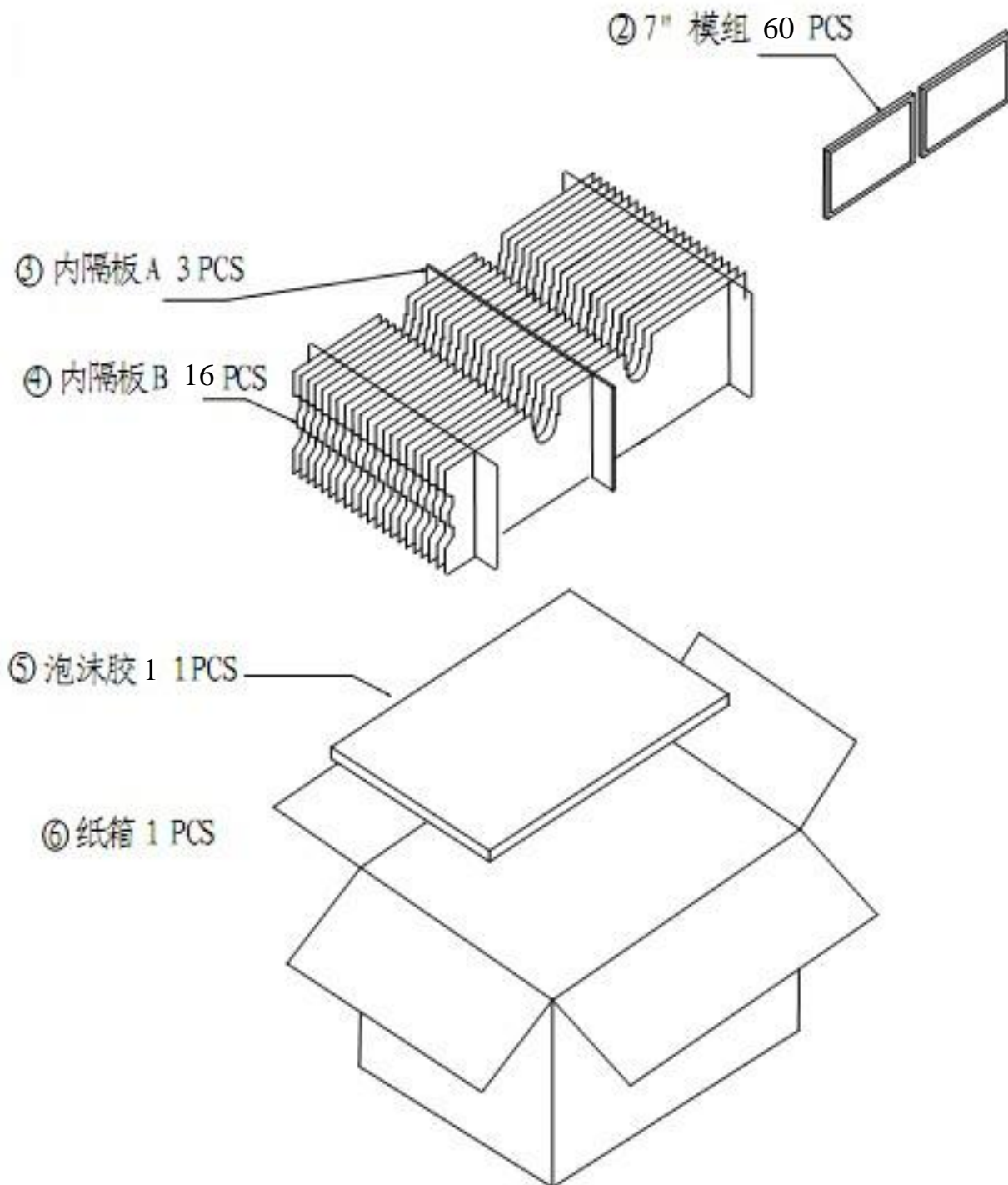

10.0 General Precaution

10.1 Use Restriction

This product is not authorized for use in life supporting systems, aircraft navigation control systems, military systems and any other application where performance failure could be life-threatening or otherwise catastrophic.

10.2 Assembly Precaution

10.2.1 Please use the mounting hole on the module side in installing and do not bending or wrenching LCD in assembling. And please do not drop, bend or twist LCD module in handling.

10.2.2 Please design display housing in accordance with the following guide lines.

10.2.2.1 Housing case must be destined carefully so as not to put stresses on LCD all sides and not to wrench module. The stresses may cause non-uniformity even if there is no non-uniformity statically.

10.2.2.2 Keep sufficient clearance between LCD module back surface and housing when the LCD module is mounted. The clearance in the design is recommended taking into account the tolerance of LCD module thickness and mounting structure height on the housing.

10.2.3 Please do not push or scratch LCD panel surface with any-thing hard. And do not soil LCD panel surface by touching with bare hands. (Polarizer film, surface of LCD panel is easy to be flawed.)

10.2.4 Please do not press any parts on the rear side such as source IC, gate IC, and FPC during handling LCD module. If pressing rear part is unavoidable, handle the LCD module with care not to damage them.

10.2.5 Please wipe out LCD panel surface with absorbent cotton or soft cloth in case of it being soiled.

10.2.6 Please wipe out drops of adhesives like saliva and water on LCD panel surface immediately. They might damage to cause panel surface variation and color change.

10.2.7 Please do not take a LCD module to pieces and reconstruct it. Resolving and reconstructing modules may cause them not to work well.

10.3 Disassembling or Modification

Do not disassemble or modify the module. It may damage sensitive parts inside LCD module, and may cause scratches or dust on the display. HannStar does not warrant the module, if customers disassemble or modify the module.

10.4 Breakage of LCD Panel

10.4.1 If LCD panel is broken and liquid crystal spills out, do not ingest or inhale liquid crystal, and do not contact liquid crystal with skin.

10.4.2 If liquid crystal contacts mouth or eyes, rinse out with water immediately.

10.4.3 If liquid crystal contacts skin or cloths, wash it off immediately with alcohol and rinse thoroughly with water.

10.4.4 Handle carefully with chips of glass that may cause injury, when the glass is broken.

10.5 Absolute Maximum Ratings and Power Protection Circuit

10.5.1 Do not exceed the absolute maximum rating values, such as the supply voltage variation, input voltage variation, variation in parts' parameters, environmental temperature, etc., otherwise LCD module may be damaged.

10.5.2 Please do not leave LCD module in the environment of high humidity and high temperature for a long time.

10.5.3 It's recommended employing protection circuit for power supply.

10.6 Operation

10.6.1 Do not touch, push or rub the polarizer with anything harder than HB pencil lead. Use fingerstalls of soft gloves in order to keep clean display quality, when persons handle the LCD module for incoming inspection or assembly.

10.6.2 When the surface is dusty, please wipe gently with absorbent cotton or other soft material.

10.6.3 Wipe off saliva or water drops as soon as possible. If saliva or water drops contact with polarizer for a long time, they may causes deformation or color fading.

10.6.4 When cleaning the adhesives, please use absorbent cotton wetted with a little petroleum benzine or other adequate solvent.

10.7 Static Electricity

10.7.1 Protection film must remove very slowly from the surface of LCD module to prevent from electrostatic occurrence.

10.7.2 Because LCD module uses CMOS-IC on TFT-LCD panel, it is very weak to electrostatic discharge. Please be careful with electrostatic discharge.

10.7.3 Persons who handle the module should be grounded through adequate methods.

10.8 Disposal

When disposing LCD module, obey the local environmental regulations.

10.9 OTHERS

10.9.1 A strong incident light into LCD panel might cause display characteristics' changing inferior because of polarizer film, color filter, and other materials becoming inferior.

Please do not expose LCD module direct sunlight land strong UV rays.

10.9.2 Please pay attention to a panel side of LCD module not to contact with other materials in preserving it alone.

10.9.3 For the packaging box, please pay attention to the followings:

10.9.3.1 Packaging box and inner case for LCD are designed to protect the LCDs from the damage or scratching during transportation. Please do not open except picking LCDs up from the box.

10.9.3.2 Please do not pile them up more than 6 boxes. (They are not designed so.) And please do not turn over.

10.9.3.3 Please handle packaging box with care not to give them sudden shock and vibrations. And also please do not throw them up.

10.9.3.4 Packing box and inner case for LCDs are made of cardboard. So please pay attention not to get them wet. (Such like keeping them in high humidity or wet place can occur getting them wet.)