

**AMELIN**

**深圳市阿美林电子科技有限公司**

**Shenzhen Amelin Electronic Technology Co. Ltd.**

SPEC. NUMBER

PRODUCT GROUP

Rev.

ISSUE DATE

PAGE

TFT-LCD

P0

1 OF 33

**HB133WX1- 201**

**Preliminary Product Specification**

**Rev. P0**



<b>AMELIN</b>	<b>PRODUCT GROUP</b>	REV	ISSUE DATE
	TFT- LCD PRODUCT	P0	
SPEC. NUMBER	SPEC. TITLE HB133WX1-201 Preliminary Product Specification		PAGE 3 OF 33

## Contents

No.	Items	Page
1.0	General Description	4
2.0	Absolute Maximum ratings	6
3.0	Electrical specifications.	7
4.0	Optical specifications.	10
5.0	Interface Connection	15
6.0	Signal Timing Specification	18
7.0	Input Signals, Display Colors & Gray Scale of Colors	20
8.0	Power Sequence	21
9.0	Connector description	22
10.0	Mechanical Characteristics	23
11.0	Reliability Test	24
12.0	Handling & Cautions.	24
13.0	Label	25
14.0	Packing information(TBD)	27
15.0	Mechanical Outline Dimension	28
16.0	EDID Table(TBD)	30

<b>AMELIN</b>	<b>PRODUCT GROUP</b>	REV	ISSUE DATE
	TFT- LCD PRODUCT	P0	
SPEC. NUMBER	SPEC. TITLE	PAGE	
	HB133WX1-201 Preliminary Product Specification	4 OF 33	

# 1.0 GENERAL DESCRIPTION

## 1.1 Introduction

HB133WX1-201 is a color active matrix TFT LCD module using amorphous silicon TFT's (Thin Film Transistors) as an active switching devices. This module has a 13.3 inch diagonally measured active area with HD resolutions (1366 horizontal by 768 vertical pixel array). Each pixel is divided into RED, GREEN, BLUE dots which are arranged in vertical Stripe and this module can display 262K colors. The TFT-LCD panel used for this module is a low reflection and higher color type. Therefore, this module is suitable for Notebook PC. The LED Driver for back-light driving is built in this model. All input signals are EDP1.2 interface compatible.

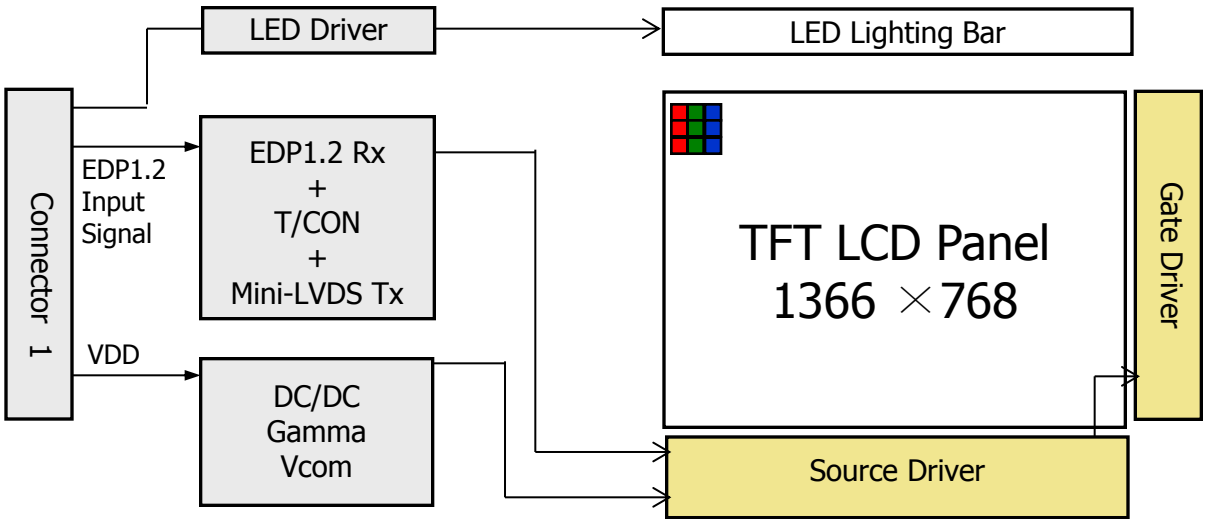

## 1.2 Features

- 1 lane EDP1.2 interface
- Thin and light weight
- 6-bit color depth, display 262K colors
- Single LED lighting bar. (Down side/Horizontal direction)
- Data enable signal mode
- Up/Down mounting frame
- Green product (ROHS & Halogen free product)
- On board LED driving circuit
- Low driving voltage and low power consumption
- On board EDID and Timing integrated into one chip

**1.3 Application**

- Notebook PC (Wide type)

**1.4 General Specification**

The followings are general specifications at the model HB133WX1-201 (listed in Table 1.)

<Table 1. General Specifications>

Parameter	Specification	Unit	Remarks
Active area	293.4168(H) × 164.9664 (V)	mm	
Number of pixels	1366 (H) × 768 (V)	pixels	
Pixel pitch	0.2148(H) × 0.2148 (V)	mm	
Pixel arrangement	RGB Vertical stripe		
Display colors	262K	colors	
Display mode	Normally White		
Dimensional outline	314.1(H)*188.7(V)*3.6(T)(max)	mm	
Weight	295(max)	g	
Surface treatment	Anti-glare		
Back-light	Lower edge side, 1-LED Lighting Bar type		Note 1
Power consumption	P <sub>D</sub> : 0.8 (max)	W	
	P <sub>BL</sub> : 2.1 (max)	W	
	P <sub>total</sub> : 2.9 (max)	W	

Notes : 1. LED Lighting Bar (36\*LED Array)

<b>AMELIN</b>	<b>PRODUCT GROUP</b>	REV	ISSUE DATE
	TFT- LCD PRODUCT	P0	
SPEC. NUMBER	SPEC. TITLE	PAGE	
	HB133WX1-201 Preliminary Product Specification	6 OF 33	

## 2.0 ABSOLUTE MAXIMUM RATINGS

The followings are maximum values which, if exceed, may cause faulty operation or damage to the unit. The operational and non-operational maximum voltage and current values are listed in Table 2.

< Table 2. Absolute Maximum Ratings > Ta=25+/-2°C

Parameter	Symbol	Min.	Max.	Unit	Remarks
Power Supply Voltage	V <sub>DD</sub>	-0.3	4.0	V	Note 1
Logic Supply Voltage	V <sub>IN</sub>	V <sub>SS</sub> -0.3	V <sub>DD</sub> +0.3	V	
Operating Temperature	T <sub>OP</sub>	0	+50	°C	Note 2
Storage Temperature	T <sub>ST</sub>	-20	+60	°C	

- Notes : 1. Permanent damage to the device may occur if maximum values are exceeded, functional operation should be restricted to the condition described under normal operating conditions.
2. Temperature and relative humidity range are shown in the figure below.  
 95 % RH Max. ( 40 °C ≥ Ta)  
 Maximum wet - bulb temperature at 39 °C or less. (Ta > 40 °C) No condensation.

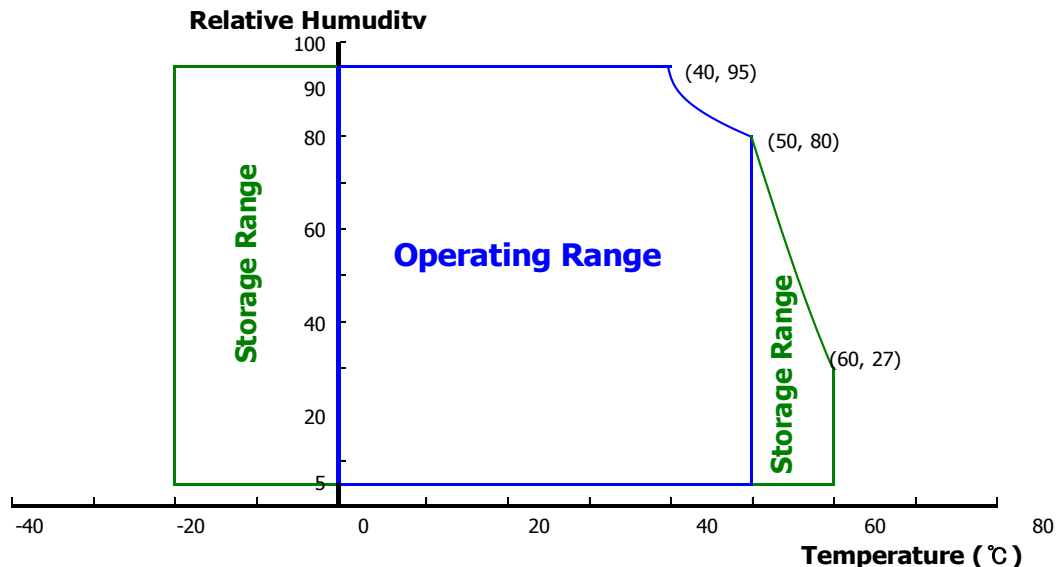

<b>AMELIN</b>	<b>PRODUCT GROUP</b>	REV	ISSUE DATE
	TFT- LCD PRODUCT	P0	
SPEC. NUMBER	SPEC. TITLE		PAGE
	HB133WX1-201 Preliminary Product Specification		7 OF 33

**3.0 ELECTRICAL SPECIFICATIONS**

**3.1 Electrical Specifications**

< Table 3. Electrical Specifications >

Ta=25+/-2°C

Parameter		Min.	Typ.	Max.	Unit	Remarks
Power Supply Voltage	V <sub>DD</sub>	3.0	3.3	3.6	V	Note 1
Permissible Input Ripple Voltage	V <sub>RF</sub>	-	-	100	mV	At V <sub>DD</sub> = 3.3V
Power Supply Current	I <sub>DD</sub>	-	240	-	mA	Note 1
Positive-going Input Threshold Voltage	V <sub>IT+</sub>	-	-	100	mV	V <sub>cm</sub> = 1.2V typ.
Negative-going Input Threshold Voltage	V <sub>IT-</sub>	-100	-	-	mV	
Differential Input Voltage	V <sub>ID</sub>	200	-	600	mV	
Power Consumption	P <sub>D</sub>	-	0.8	1.0	W	Note 1
	P <sub>BL</sub>	-	-	2.1	W	Note 2
	P <sub>total</sub>	-	2.9	3.0	W	

Notes : 1. The supply voltage is measured and specified at the interface connector of LCM.  
 The current draw and power consumption specified is for 3.3V at 25°C.  
 a) Typ : Window XP pattern  
 b) Max : Vertical 2 line skip pattern



2. Calculated value for reference (V<sub>LED</sub> × I<sub>LED</sub>)

### 3.0 ELECTRICAL SPECIFICATIONS

#### 3.2 Backlight Unit

< Table 4. LED Driving Guideline Specifications >

Ta=25+/-2°C

Parameter		Min.	Typ.	Max.	Unit	Remarks
LED Forward Voltage	V <sub>F</sub>	-	-	3.0	V	-
LED Forward Current	I <sub>F</sub>	-	18.6		mA	-
LED Power Consumption	P <sub>LED</sub>			2.1	W	Note 1
LED Life-Time	N/A	15,000	-	-	Hour	I <sub>F</sub> = 20mA
Power supply voltage for LED Driver	V <sub>LED</sub>	5	12	21	V	
EN Control Level	Backlight on	2.0		3.6	V	
	Backlight off	0		1.0	V	
PWM Control Level	PWM High Level	2.0		3.6	V	
	PWM Low Level	0		0.1	V	
PWM Control Frequency	F <sub>PWM</sub>	100	-	10,000	Hz	
Duty Ratio	-	3	-	100	%	

Notes : 1. Power supply voltage 12V for LED Driver, Driver efficiency 90%,

Calculator Value for reference  $I_F \times V_F \times 36 / 0.9 = P_{LED}$

2. The LED Life-time define as the estimated time to 50% degradation of initial luminous.



### 3.0 ELECTRICAL SPECIFICATIONS

#### 3.3 LED structure

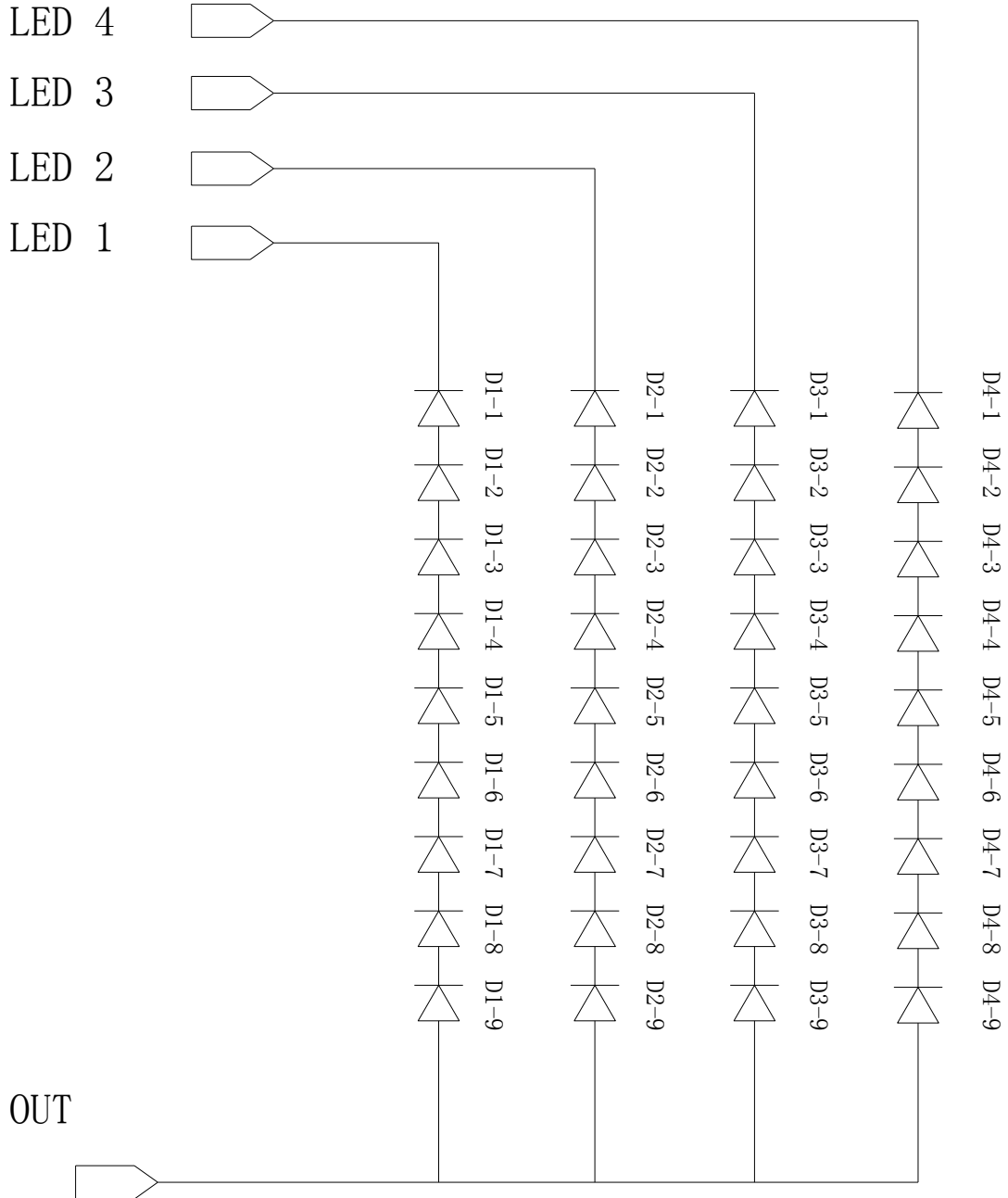

<b>AMELIN</b>	<b>PRODUCT GROUP</b>	REV	ISSUE DATE
	TFT- LCD PRODUCT	P0	
SPEC. NUMBER	SPEC. TITLE	PAGE	
	HB133WX1-201 Preliminary Product Specification	10 OF 33	

## 4.0 OPTICAL SPECIFICATION

### 4.1 Overview

The test of optical specifications shall be measured in a dark room (ambient luminance  $\leq 1$  lux and temperature =  $25 \pm 2^\circ\text{C}$ ) with the equipment of luminance meter system (Goniometer system and TOPCON BM-5) and test unit shall be located at an approximate distance 50cm from the LCD surface at a viewing angle of  $\theta$  and  $\Phi$  equal to  $0^\circ$ . We refer to  $\theta\emptyset=0$  ( $=\theta_3$ ) as the 3 o'clock direction (the "right"),  $\theta\emptyset=90$  ( $=\theta_{12}$ ) as the 12 o'clock direction ("upward"),  $\theta\emptyset=180$  ( $=\theta_9$ ) as the 9 o'clock direction ("left") and  $\theta\emptyset=270$  ( $=\theta_6$ ) as the 6 o'clock direction ("bottom"). While scanning  $\theta$  and/or  $\emptyset$ , the center of the measuring spot on the display surface shall stay fixed. The backlight should be operating for 30 minutes prior to measurement. VDD shall be  $3.3 \pm 0.3\text{V}$  at  $25^\circ\text{C}$ . Optimum viewing angle direction is 6 'clock.

### 4.2 Optical Specifications

<Table 5. Optical Specifications>

Parameter		Symbol	Condition	Min.	Typ.	Max.	Unit	Remark
Viewing Angle range	Horizontal	$\Theta_3$	CR > 10	-	45	-	Deg.	Note 1
		$\Theta_9$		-	45	-	Deg.	
	Vertical	$\Theta_{12}$		-	20	-	Deg.	
		$\Theta_6$		-	40	-	Deg.	
Luminance Contrast ratio		CR	$\Theta = 0^\circ$	-	500	-		Note 2
Luminance of White	5 Points	$Y_w$	$\Theta = 0^\circ$ $I_{LED} = 20\text{mA}$	170	200	-	$\text{cd/m}^2$	Note 3
White Luminance uniformity	5 Points	$\Delta Y_5$		80	-	-		Note 4
	13 Points	$\Delta Y_{13}$		65	-	-		
White Chromaticity		$x_w$	$\Theta = 0^\circ$	0.283	0.313	0.343		Note 5
		$y_w$		0.299	0.329	0.359		
Reproduction of color	Red	$x_R$	$\Theta = 0^\circ$	-0.03	0.592	+0.03		
		$y_R$			0.349			
	Green	$x_G$			0.333			
		$y_G$			0.569			
	Blue	$x_B$			0.159			
		$y_B$			0.126			
Response Time (Rising + Falling)		$T_{RT}$	$T_a = 25^\circ\text{C}$ $\Theta = 0^\circ$	-	12	16	ms	Note 6
Cross Talk		CT	$\Theta = 0^\circ$	-	-	2	%	Note 7

AMELIN	PRODUCT GROUP	REV	ISSUE DATE
	TFT- LCD PRODUCT	P0	
SPEC. NUMBER	SPEC. TITLE	PAGE	
	HB133WX1-201 Preliminary Product Specification	11 OF 33	

Notes :

1. Viewing angle is the angle at which the contrast ratio is greater than 10. The viewing angles are determined for the horizontal or 3, 9 o'clock direction and the vertical or 6, 12 o'clock direction with respect to the optical axis which is normal to the LCD surface (see FIGURE 1).

2. Contrast measurements shall be made at viewing angle of  $\Theta = 0$  and at the center of the LCD surface. Luminance shall be measured with all pixels in the view field set first to white, then to the dark (black) state .  
(see FIGURE 1) Luminance Contrast Ratio (CR) is defined mathematically.

$$CR = \frac{\text{Luminance when displaying a white raster}}{\text{Luminance when displaying a black raster}}$$

3. Center Luminance of white is defined as luminance values of 5 point average across the LCD surface. Luminance shall be measured with all pixels in the view field set first to white. This measurement shall be taken at the locations shown in FIGURE 2 for a total of the measurements per display.

4. The white luminance uniformity on LCD surface is then expressed as :  $\Delta Y = \text{Minimum Luminance of 5(or 13) points} / \text{Maximum Luminance of 5(or 13) points}$ .  
(see FIGURE 2 and FIGURE 3).

5. The color chromaticity coordinates specified in Table 5 shall be calculated from the spectral data measured with all pixels first in red, green, blue and white. Measurements shall be made at the center of the panel.

6. The electro-optical response time measurements shall be made as FIGURE 4 by switching the "data" input signal ON and OFF. The times needed for the luminance to change from 10% to 90% is  $T_r$ , and 90% to 10% is  $T_d$ .

7. Cross-Talk of one area of the LCD surface by another shall be measured by comparing the luminance (YA) of a 25mm diameter area, with all display pixels set to a gray level, to the luminance (YB) of that same area when any adjacent area is driven dark.  
(See FIGURE 5).

<b>AMELIN</b>	<b>PRODUCT GROUP</b>	REV	ISSUE DATE
	TFT- LCD PRODUCT	P0	
SPEC. NUMBER	SPEC. TITLE		PAGE
	HB133WX1-201 Preliminary Product Specification		12 OF 33

**4.3 Optical Measurements**

**Figure 1. Measurement Set Up**

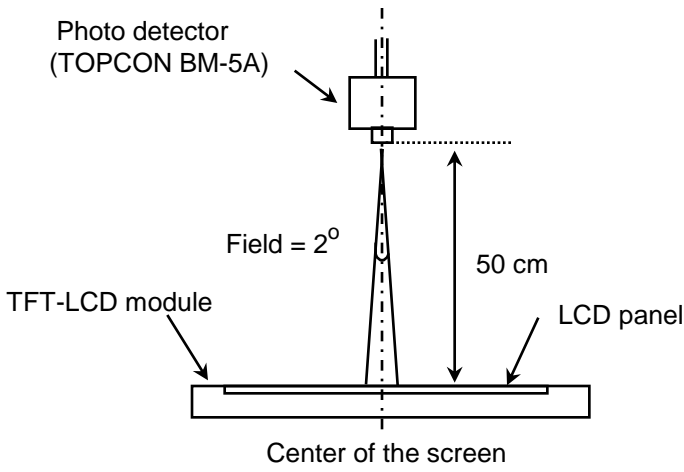

Optical characteristics measurement setup

**Figure 2. White Luminance and Uniformity Measurement Locations (5 points)**

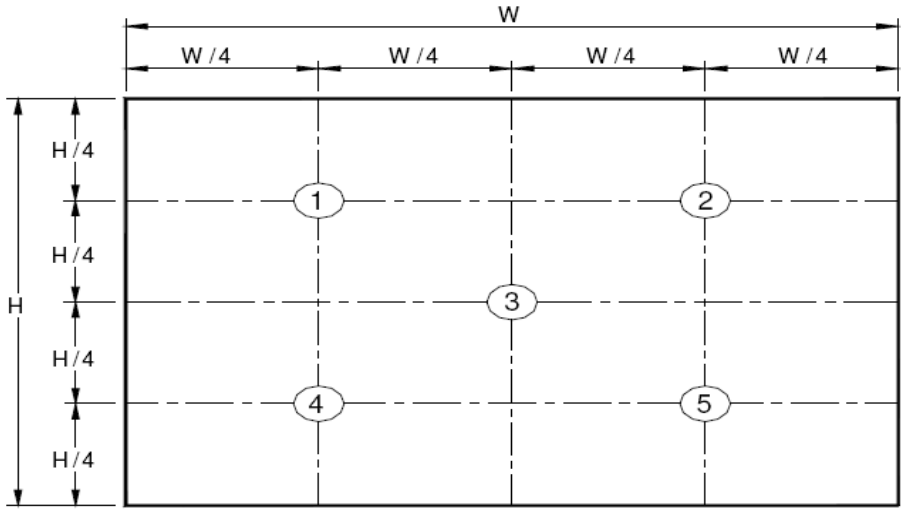

Center luminance of white is defined as luminance values of center 5 points across the LCD surface. Luminance shall be measured with all pixels in the view field set first to white. This measurement shall be taken at the locations shown in FIGURE 2 for a total of the measurements per display.

<b>AMELIN</b>	<b>PRODUCT GROUP</b>	REV	ISSUE DATE
	TFT- LCD PRODUCT	P0	
SPEC. NUMBER	SPEC. TITLE		PAGE
	HB133WX1-201 Preliminary Product Specification		13 OF 33

**Figure 3. Uniformity Measurement Locations (13 points)**

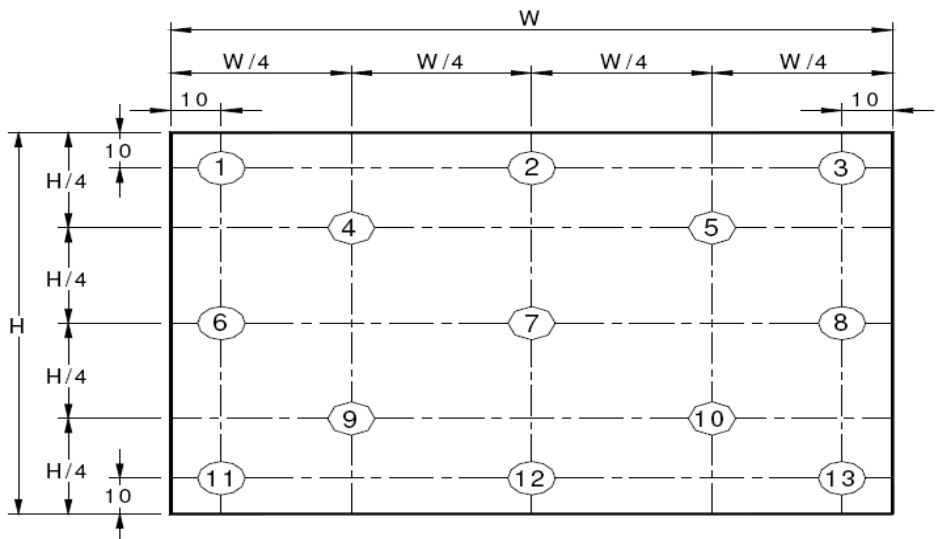

The white luminance uniformity on LCD surface is then expressed as :  $\Delta Y5 = \text{Minimum Luminance of five points} / \text{Maximum Luminance of five points}$  (see FIGURE 2) ,  $\Delta Y13 = \text{Minimum Luminance of 13 points} / \text{Maximum Luminance of 13 points}$  (see FIGURE 3).

**Figure 4. Response Time Testing**

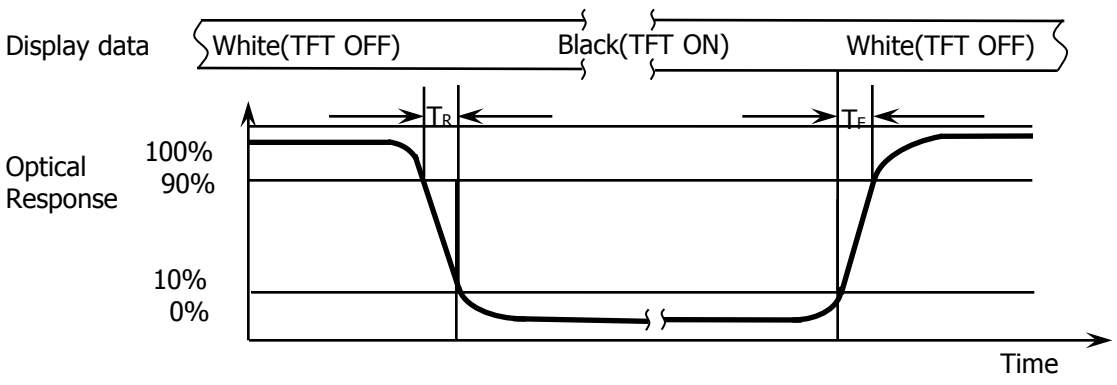

The electro-optical response time measurements shall be made as shown in FIGURE 4 by switching the “data” input signal ON and OFF. The times needed for the luminance to change from 10% to 90% is  $T_d$  and 90% to 10% is  $T_r$ .

**Figure 5. Cross Modulation Test Description**

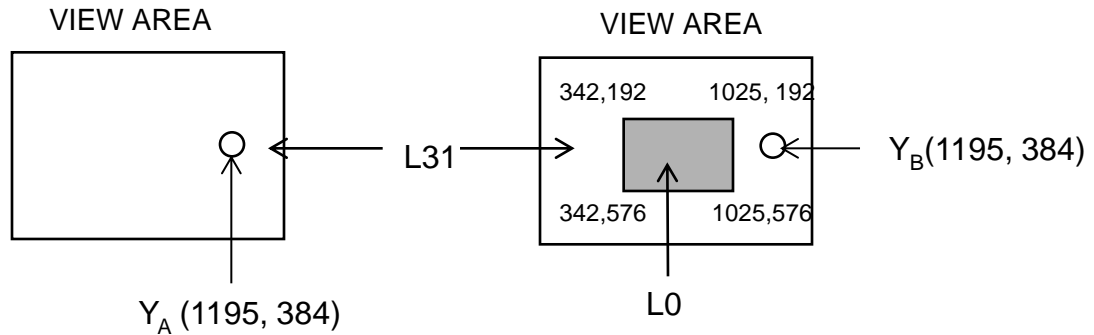

$$\text{Cross-Talk (\%)} = \left| \frac{Y_B - Y_A}{Y_A} \right| \times 100$$

Where:

$Y_A$  = Initial luminance of measured area (cd/m<sup>2</sup>)

$Y_B$  = Subsequent luminance of measured area (cd/m<sup>2</sup>)

The location measured will be exactly the same in both patterns

Cross-Talk of one area of the LCD surface by another shall be measured by comparing the luminance ( $Y_A$ ) of a 25mm diameter area, with all display pixels set to a gray level, to the luminance ( $Y_B$ ) of that same area when any adjacent area is driven dark (Refer to FIGURE 5).

### 5.0 INTERFACE CONNECTION.

#### 5.1 Electrical Interface Connection

The electronics interface connector is STM or Compatible or equivalent. The mating connector part number is I-PEX 20454-030T or Compatible. The connector interface pin assignments are listed in Table 6.

<Table 6. Pin Assignments for the Interface Connector>

Terminal	Symbol	Functions
Pin No.	Symbol	Description
1	CABC_ENABLE	test enable
2	H_GND	Ground
3	NC	No Connection
4	NC	No Connection
5	H_GND	Ground
6	LANE0_N	eDP RX channel 0 negative
7	LANE0_P	eDP RX channel 0 positive
8	H_GND	Ground
9	AUX_CH_P	eDP AUX CH positive
10	AUX_CH_N	eDP AUX CH negative
11	H_GND	Ground
12	LCD_VCC	Power Supply, 3.3V (typ.)
13	LCD_VCC	Power Supply, 3.3V (typ.)
14	LCD_Self_Test	Panel self test enable
15	H_GND	Ground
16	H_GND	Ground
17	HPD	Hot plug detect output
18	BL_GND	LED Ground
19	BL_GND	LED Ground
20	BL_GND	LED Ground
21	BL_GND	LED Ground
22	BL_ENABLE	LED enable pin(+3.3V Input)
23	BL_PWM	System PWM Signal Input
24	NC	No Connection
25	COLOR_ENABLE	test enable
26	BL_POWER	LED Power Supply 5V-21V
27	BL_POWER	LED Power Supply 5V-21V
28	BL_POWER	LED Power Supply 5V-21V
29	BL_POWER	LED Power Supply 5V-21V
30	NC	No Connection

### 5-2. EDP1.2 Interface

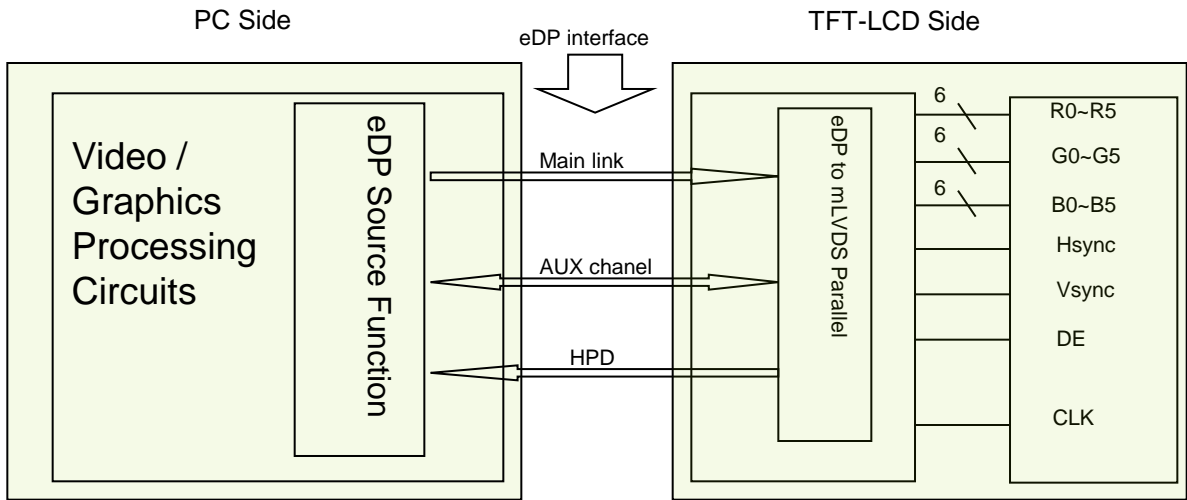

Note. Transmitter : Parade DP611E or equivalent.  
 Transmitter is not contained in Module.

### 5.3. EDP1.2 Input signal

Lane0	
R0-5:0	G0-5:4
G0-3:0	B0-5:2
B0-1:0	R1-5:0
G1-5:0	B1-5:4
B1-3:0	R2-5:2
R2-1:0	G2-5:0
B2-5:0	R3-5:4
R3-3:0	G3-5:2
G3-1:0	B3-5:0



### 5.4 Back-light & LCM Interface Connection

Interface Connector: MS24022P10 or Equivalent

<Table 7. Pin Assignments for the BLU & LCM Connector>

Pin No.	Symbol	Description	Pin No.	Symbol	Description
1	LED1	LED cathode connection	6	NC	No Connection
2	LED2	LED cathode connection	7	NC	No Connection
3	LED3	LED cathode connection	8	Vout	LED anode connection
4	LED4	LED cathode connection	9	Vout	LED anode connection
5	NC	No Connection	10	Vout	LED anode connection

### 6.0 SIGNAL TIMING SPECIFICATION

6.1 The HB133WX1-201 is operated by the DE only.

Item		Symbols	Min	Typ	Max	Unit
Clock	Frequency	1/Tc	67.5	71.72	76.3	MHz
	High Time	Tch	-	4/7	-	Tc
	Low Time	Tcl	-	3/7	-	Tc
Frame Period		Tv	778	790	802	lines
			-	60	-	Hz
			-	16.7	-	ms
Vertical Display Period		Tvd	768	768	768	lines
One line Scanning Period		Th	1446	1513	1586	clocks
Horizontal Display Period		Thd	1366	1366	1366	clocks

<b>AMELIN</b>	<b>PRODUCT GROUP</b>	REV	ISSUE DATE
	TFT- LCD PRODUCT	P0	
SPEC. NUMBER	SPEC. TITLE HB133WX1-201 Preliminary Product Specification		PAGE 19 OF 33

**6.2 eDP Rx Interface Timing Parameter**

The specification of the eDP Rx interface timing parameter is shown in Table 8.

<Table 8. eDP Rx Interface Timing Specification>

Item	Symbol	Min	Typ	Max	Unit	Remark
Spread spectrum clock	SSC		0.5		%	
Differential peak-to-peak input voltage at package pins	VRX-DIFFp-p	100	0	1320	mV	
Rx input DC common mode voltage	VRX_DC_CM	-	GND	-	V	
Differential termination resistance	RRX-DIFF	80	-	100	$\Omega$	
Single-ended termination resistance	RRX-SE	40	-	60	$\Omega$	
Rx short circuit current limit	IRX_SHORT	-	-	20	mA	
Intra-pair skew at Rx package pins (HBR) RX intra-pair skew tolerance at HBR	LRX_SKEW_INTRA_PAIR	-	-	150	ps	

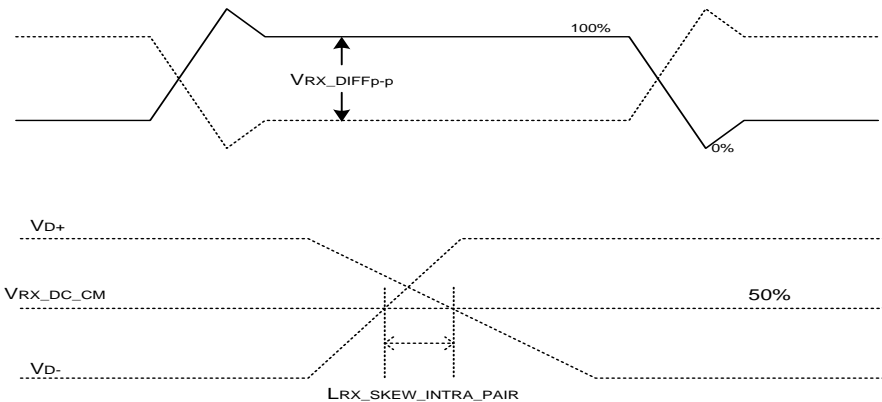

### 7.0 INPUT SIGNALS, BASIC DISPLAY COLORS & GRAY SCALE OF COLORS

	Colors & Gray scale	Data signal																	
		R0	R1	R2	R3	R4	R5	G0	G1	G2	G3	G4	G5	B0	B1	B2	B3	B4	B5
Basic colors	Black	0	0	0	0	0	0	0	0	0	0	0	0	0	0	0	0	0	0
	Blue	0	0	0	0	0	0	0	0	0	0	0	0	1	1	1	1	1	1
	Green	0	0	0	0	0	0	1	1	1	1	1	1	0	0	0	0	0	0
	Light Blue	0	0	0	0	0	0	1	1	1	1	1	1	1	1	1	1	1	1
	Red	1	1	1	1	1	1	0	0	0	0	0	0	0	0	0	0	0	0
	Purple	1	1	1	1	1	1	0	0	0	0	0	0	1	1	1	1	1	1
	Yellow	1	1	1	1	1	1	1	1	1	1	1	1	0	0	0	0	0	0
	White	1	1	1	1	1	1	1	1	1	1	1	1	1	1	1	1	1	1
Gray scale of Red	Black	0	0	0	0	0	0	0	0	0	0	0	0	0	0	0	0	0	0
	△	1	0	0	0	0	0	0	0	0	0	0	0	0	0	0	0	0	0
	Darker	0	1	0	0	0	0	0	0	0	0	0	0	0	0	0	0	0	0
	△	↑						↑						↑					
	▽	↓						↓						↓					
	Brighter	1	0	1	1	1	1	0	0	0	0	0	0	0	0	0	0	0	0
	▽	0	1	1	1	1	1	0	0	0	0	0	0	0	0	0	0	0	0
	Red	1	1	1	1	1	1	0	0	0	0	0	0	0	0	0	0	0	0
Gray scale of Green	Black	0	0	0	0	0	0	0	0	0	0	0	0	0	0	0	0	0	0
	△	0	0	0	0	0	0	1	0	0	0	0	0	0	0	0	0	0	0
	Darker	0	0	0	0	0	0	0	1	0	0	0	0	0	0	0	0	0	0
	△	↑						↑						↑					
	▽	↓						↓						↓					
	Brighter	0	0	0	0	0	0	1	0	1	1	1	1	0	0	0	0	0	0
	▽	0	0	0	0	0	0	0	1	1	1	1	1	0	0	0	0	0	0
	Green	0	0	0	0	0	0	1	1	1	1	1	1	0	0	0	0	0	0
Gray scale of Blue	Black	0	0	0	0	0	0	0	0	0	0	0	0	0	0	0	0	0	0
	△	0	0	0	0	0	0	0	0	0	0	0	0	1	0	0	0	0	0
	Darker	0	0	0	0	0	0	0	0	0	0	0	0	0	1	0	0	0	0
	△	↑						↓						↑					
	▽	↓						↓						↓					
	Brighter	0	0	0	0	0	0	0	0	0	0	0	0	1	0	1	1	1	1
	▽	0	0	0	0	0	0	0	0	0	0	0	0	0	1	1	1	1	1
	Blue	0	0	0	0	0	0	0	0	0	0	0	0	1	1	1	1	1	1
Gray scale of White & Black	Black	0	0	0	0	0	0	0	0	0	0	0	0	0	0	0	0	0	0
	△	1	0	0	0	0	0	1	0	0	0	0	0	1	0	0	0	0	0
	Darker	0	1	0	0	0	0	0	1	0	0	0	0	0	1	0	0	0	0
	△	↑						↑						↑					
	▽	↓						↓						↓					
	Brighter	1	0	1	1	1	1	1	0	1	1	1	1	1	0	1	1	1	1
	▽	0	1	1	1	1	1	0	1	1	1	1	1	0	1	1	1	1	1
	White	1	1	1	1	1	1	1	1	1	1	1	1	1	1	1	1	1	1

### 8.0 POWER SEQUENCE

To prevent a latch-up or DC operation of the LCD module, the power on/off sequence shall be as shown in below

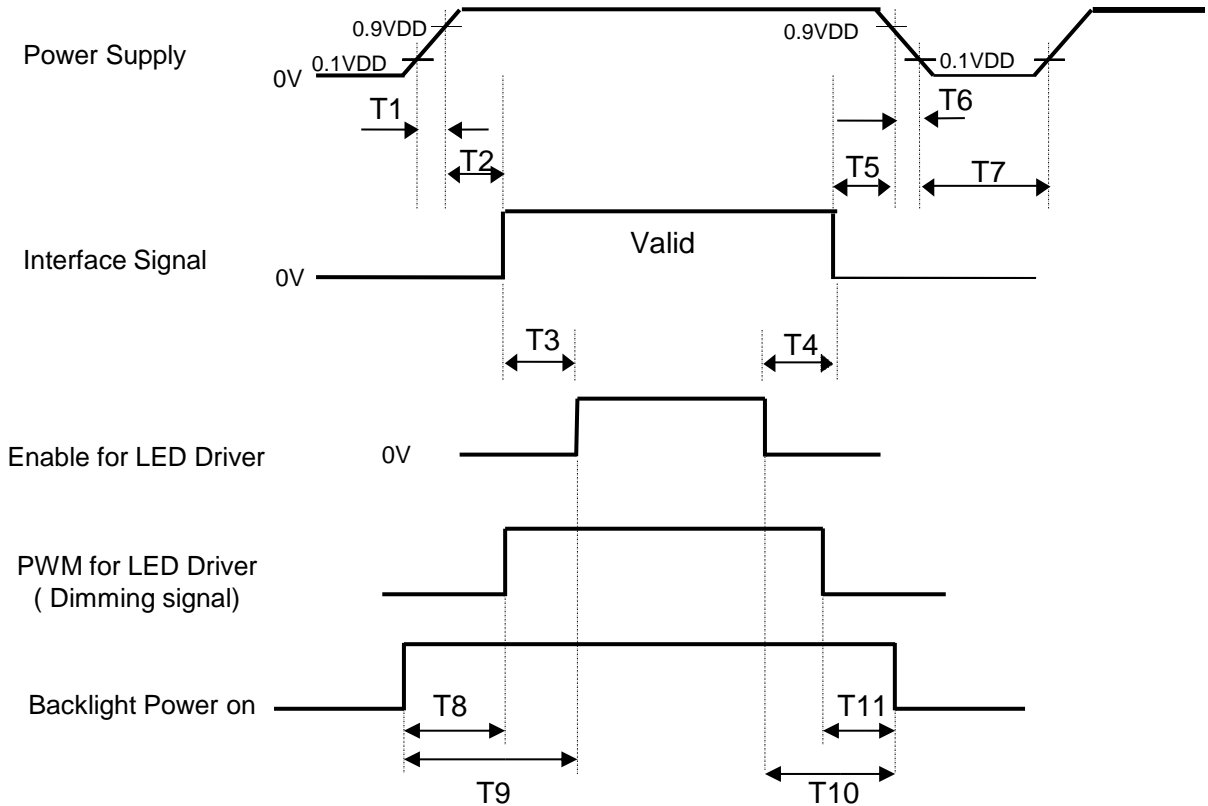

- 0.5ms ≤ T1 ≤ 10 ms
- 0 ms ≤ T2 ≤ 400 ms
- 200 ms ≤ T3
- 0 ms ≤ T4
- 0ms ≤ T5
- 0 ms ≤ T6 ≤ 10 ms
- 150ms ≤ T7
- 0 ms ≤ T8
- 0 ms ≤ T9
- 0ms ≤ T10
- 0ms ≤ T11

#### Notes:

1. When the power supply VDD is 0V, keep the level of input signals on the low or keep high impedance.
2. Do not keep the interface signal high impedance when power is on. Back Light must be turn on after power for logic and interface signal are valid.

### 9.0 Connector Description

Physical interface is described as for the connector on LCM.

These connectors are capable of accommodating the following signals and will be following components.

#### 9.1 TFT LCD Module

Connector Name /Description	For Signal Connector
Manufacturer	STM or Compatible
Type/ Part Number	MSAK24025P30 or Compatible
Mating housing/ Part Number	I-PEX 20454-030T or Compatible

<b>AMELIN</b>	<b>PRODUCT GROUP</b>	REV	ISSUE DATE
	TFT- LCD PRODUCT	P0	
SPEC. NUMBER	SPEC. TITLE	PAGE	
	HB133WX1-201 Preliminary Product Specification	23 OF 33	

## 10.0 MECHANICAL CHARACTERISTICS

### 10.1 Dimensional Requirements

FIGURE 6 shows mechanical outlines for the model HB133WX1-201. Other parameters are shown in Table 9.

<Table 9. Dimensional Parameters>

Parameter	Specification	Unit
Active Area	293.4168(H) × 164.9664 (V)	mm
Number of pixels	1366 (H) X 768 (V) (1 pixel = R + G + B dots)	
Pixel pitch	0.2148(H) × 0.2148 (V)	mm
Pixel arrangement	RGB Vertical stripe	
Display colors	262K	
Display mode	Normally white	
Dimensional outline	314.1(±0.5)(H)*188.7(±0.5)(V)*3.6(T)(max)	mm
Weight	295 (max)	gram
Back Light	Connector : MS24022P10	
	LED, Horizontal-LED Array type	

### 10.2 Mounting

See FIGURE 6.

### 10.3 Glare and Polarizer Hardness.

The surface of the LCD has an hazed coating to achieve anti-glare effect and hard coating to reduce scratching.

### 10.4 Light Leakage

There shall not be visible light from the back-lighting system around the edges of the screen as seen from a distance 50cm from the screen with an overhead light level of 350lux.

<b>AMELIN</b>	<b>PRODUCT GROUP</b>	REV	ISSUE DATE
	TFT- LCD PRODUCT	P0	
SPEC. NUMBER	SPEC. TITLE	PAGE	
	HB133WX1-201 Preliminary Product Specification	24 OF 33	

## 11.0 RELIABILITY TEST

The Reliability test items and its conditions are shown in below.

<Table 10. Reliability test>

No	Test Items	Conditions
1	High temperature storage test	Ta = 60 °C , 240 hrs
2	Low temperature storage test	Ta = -20 °C , 240 hrs
3	High temperature & high humidity operation test	Ta = 50 °C , 80%RH, 240 hrs
4	High temperature operation test	Ta = 50 °C , 240 hrs
5	Low temperature operation test	Ta = 0 °C , 240 hrs
6	Thermal shock	Ta = -20 °C ↔ 60 °C (0.5 hr), 100 cycle
7	Vibration test (non-operating)	1.5G, 10~500Hz,Half Sine X,Y,Z / Sweep rate : 1 hour
8	Shock test (non-operating)	220G, Half Sine Wave 2msec ± X, ± Y, ± Z Once for each direction
9	Electro-static discharge test (non-operating)	Air : 150 pF, 330Ω, 15 KV Contact : 150 pF, 330Ω, 8 KV

## 12.0 HANDLING & CAUTIONS

### (1) Cautions when taking out the module

- Pick the pouch only, when taking out module from a shipping package.

### (2) Cautions for handling the module

- As the electrostatic discharges may break the LCD module, handle the LCD module with care. Peel a protection sheet off from the LCD panel surface as slowly as possible.
- As the LCD panel and back - light element are made from fragile glass material, impulse and pressure to the LCD module should be avoided.
- As the surface of the polarizer is very soft and easily scratched, use a soft dry cloth without chemicals for cleaning.
- Do not pull the interface connector in or out while the LCD module is operating.
- Put the module display side down on a flat horizontal plane.
- Handle connectors and cables with care.

### (3) Cautions for the operation

- When the module is operating, do not lose CLK, ENAB signals. If any one of these signals is lost, the LCD panel would be damaged.
- Obey the supply voltage sequence. If wrong sequence is applied, the module would be damaged.



<b>AMELIN</b>	<b>PRODUCT GROUP</b>	REV	ISSUE DATE
	TFT- LCD PRODUCT	P0	
SPEC. NUMBER	SPEC. TITLE		PAGE
	HB133WX1-201 Preliminary Product Specification		25 OF 33

- (4) Cautions for the atmosphere
- Dew drop atmosphere should be avoided.
  - Do not store and/or operate the LCD module in a high temperature and/or humidity atmosphere. Storage in an electro-conductive polymer packing pouch and under relatively low temperature atmosphere is recommended.
- (5) Cautions for the module characteristics
- Do not apply fixed pattern data signal to the LCD module at product aging.
  - Applying fixed pattern for a long time may cause image sticking.
- (6) Other cautions
- Do not disassemble and/or re-assemble LCD module.
  - Do not re-adjust variable resistor or switch etc.
  - When returning the module for repair or etc., Please pack the module not to be broken. We recommend to use the original shipping packages.

### 13.0 LABEL

(1) Product label

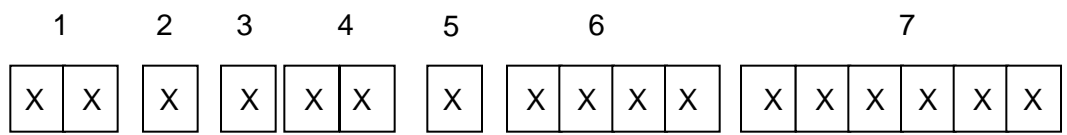
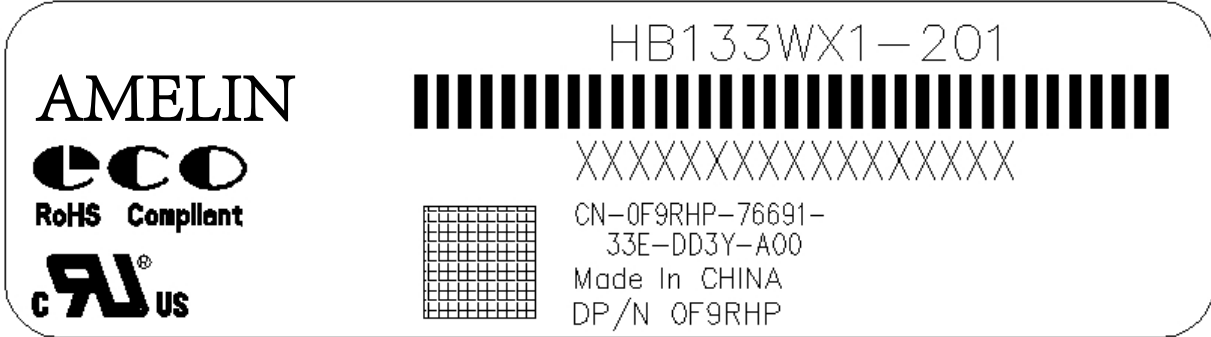

Type designation	No 5. Month (1, 2, 3, ..., 9, X, Y, Z)
No 1. Control Number	No 6. Product Identification (FG)
No 2. Rank / Grade	No 7. Serial Number
No 3. Line classification	
No 4. Year (10 : 2010, 11: 2011, ...)	

<b>AMELIN</b>	<b>PRODUCT GROUP</b>	REV	ISSUE DATE
	TFT- LCD PRODUCT	P0	
SPEC. NUMBER	SPEC. TITLE HB133WX1-201 Preliminary Product Specification		PAGE 26 OF 33

(2) Box label



- Label Size : 108 mm (L) 56 mm (W)
- Contents  
 Model : HB133WX1-201  
 Q`ty : 25pcs MDL in one box.  
 Serial No. : Box Serial No. See next page for detail description.  
 Date : Packing Date  
 FG Code : FG Code of Product

## 深圳市阿美林电子科技有限公司

Shenzhen Amelin Electronic Technology Co. Ltd.

**MODEL:** HB133WX1-201                      **Q'TY:** 25

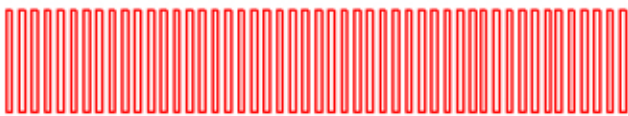
**SERIAL NO:** XXXXXXXXXXXXXXX              **DATE:** 20XX / XX / XX

序列号	1	2	3	4	5	6	7	8	9	10	11	12	13
代码	4	J	P	3	1	2	7	0	0	0	1	H	D
描述	GBN代码		等级	B3	年份		月	Rev	序列号				

AMELIN	PRODUCT GROUP	REV	ISSUE DATE
	TFT- LCD PRODUCT	P0	
SPEC. NUMBER	SPEC. TITLE	PAGE	
	HB133WX1-201 Preliminary Product Specification	27 OF 33	

## 14.0 PACKING INFORMATION(TBD)

### 14.1 Packing order

- 将 1pcs MDL 平放入Tray, Panel 面向上放置EPE Spacer
- 容量: 1pcs/Tray

step 1

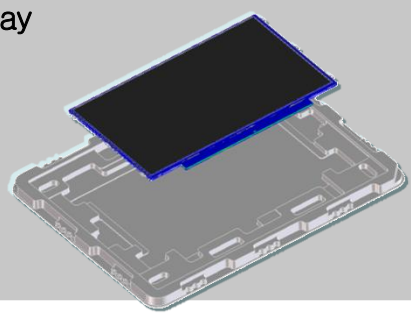

step 2

- 将26pcs PET Tray 平放入PE Bag
- 容量: 25pcs/PE Bag

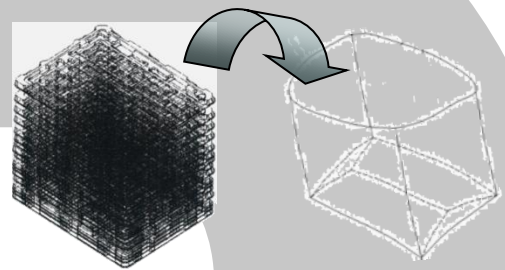

- 每个Pallet上放3层Box, 1层6箱, 共计18ea Box
- Pallet 四边及打包带位置放置纸护角后, 以缠绕膜包裹
- 容量: 450pcs/Pallet



step 4

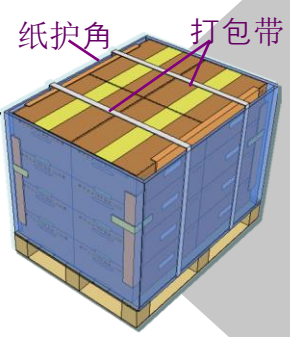

- 将PET Tray堆码后平放入Inner Box
- 上下放置EPE Board
- 容量: 25pcs/Inner Box

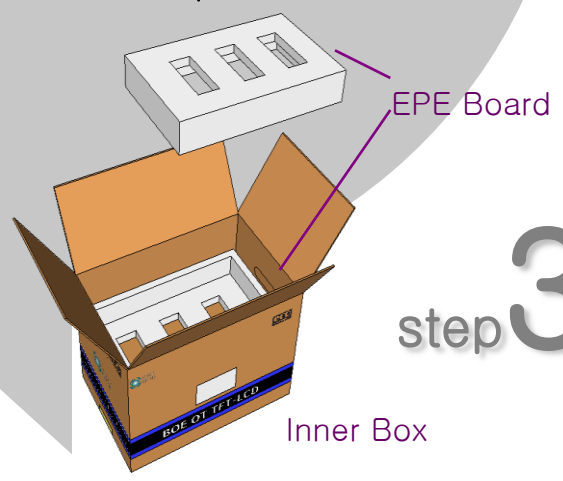

step 3

### 14.2 Notes

- Box Dimension: 500mm(W) x 400mm(D) x 290mm(H)
- Package Quantity in one Box: 25cs
- Total Weight: 11.5kg

## 15.0 MECHANICAL OUTLINE DIMENSION

Figure 6. TFT-LCD Module Outline Dimension (Front View)

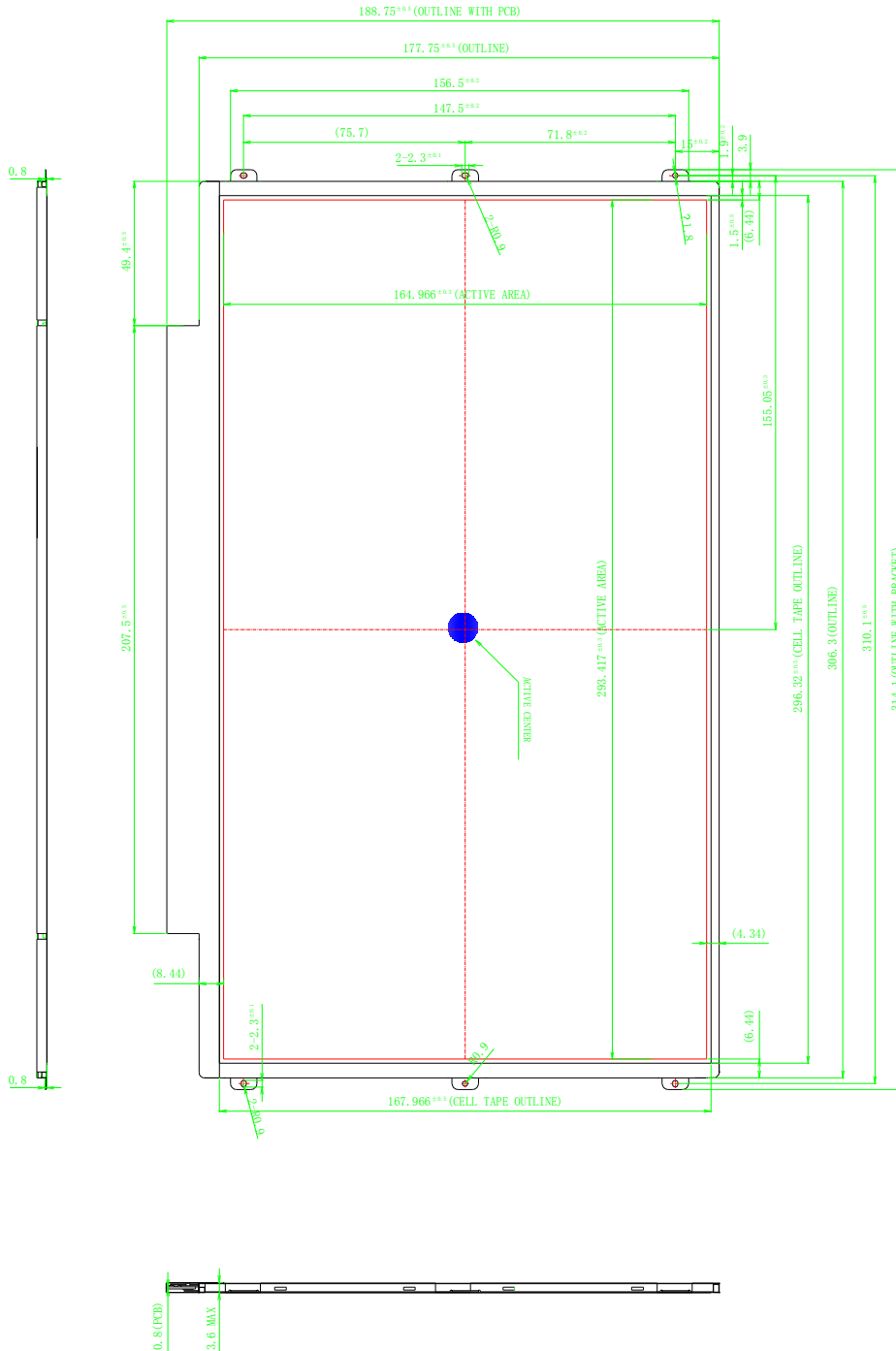

### Figure 7. TFT-LCD Module Outline Dimensions (Rear view)

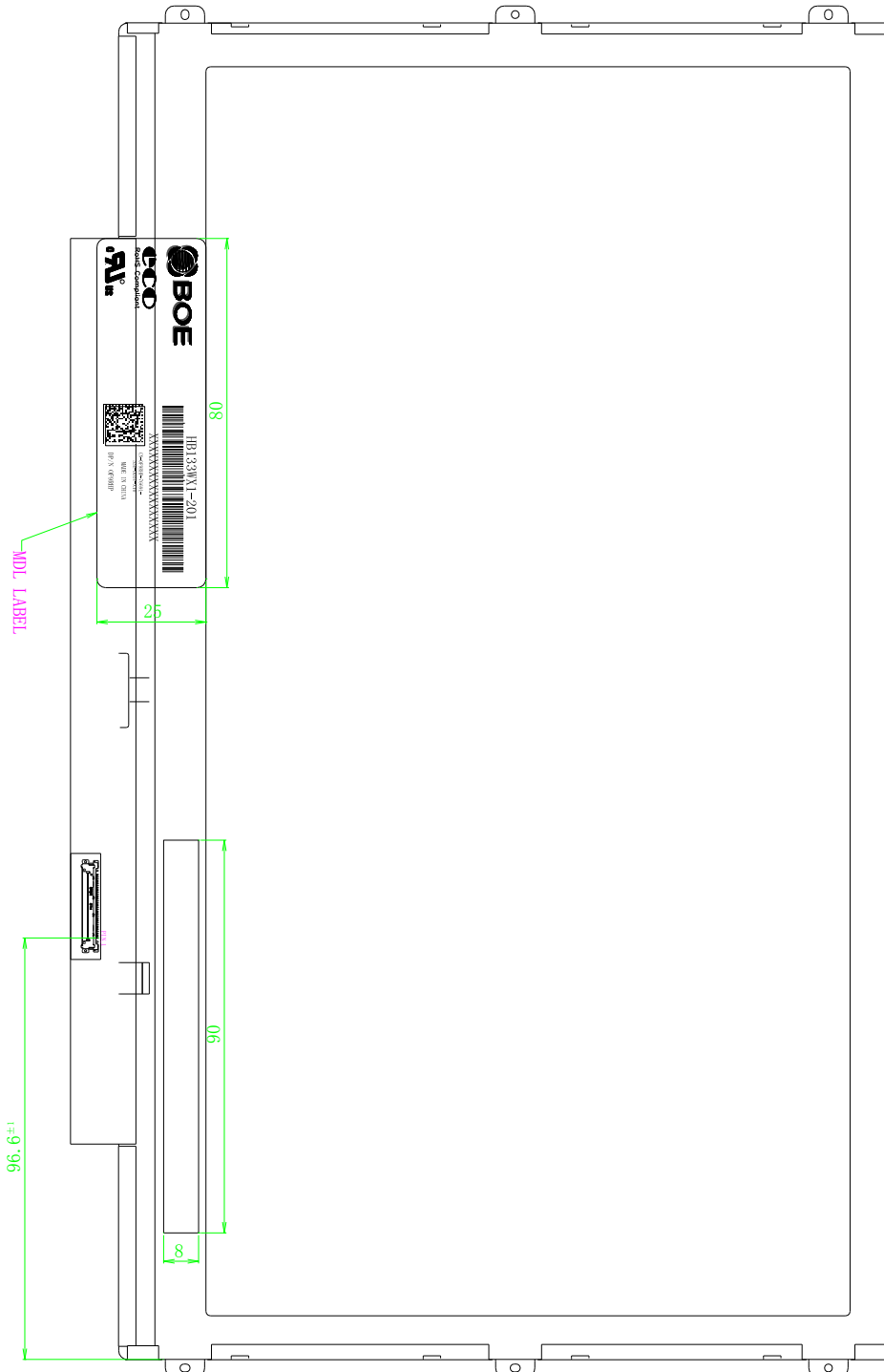

<b>AMELIN</b>	<b>PRODUCT GROUP</b>	REV	ISSUE DATE
	TFT- LCD PRODUCT	P0	
SPEC. NUMBER	SPEC. TITLE		PAGE
	HB133WX1-201 Preliminary Product Specification		30 OF 33

**16.0 EDID Table**

Address (HEX)	Function	Hex	Dec	crc	Input values.	Notes
00	Header	00	0		0	EDID Header
01		FF	255		255	
02		FF	255		255	
03		FF	255		255	
04		FF	255		255	
05		FF	255		255	
06		FF	255		255	
07		00	0		0	
08	ID Manufacturer Name	09	9		BOE	ID = BOE
09		E5	229			
0A	ID Product Code	<b>DF</b>	<b>223</b>		<b>1503</b>	ID = 1503
0B		<b>05</b>	<b>5</b>			
0C	32-bit serial No.	00	0			
0D		00	0			
0E		00	0			
0F		00	0			
10	Week of manufacture	1	1		1	
11	<b>Year of Manufacture</b>	<b>18</b>	<b>24</b>		<b>2014</b>	Manufactured in 2014
12	EDID Structure Ver.	01	1		1	EDID Ver 1.0
13	EDID revision #	<b>04</b>	<b>4</b>		<b>4</b>	<b>EDID Rev. 0.4</b>
14	Video input definition	95	149		-	
15	Max H image size	1D	29		29	29 cm (Approx)
16	Max V image size	10	16		16	16 cm (Approx)
17	Display Gamma	78	120		2.2	Gamma curve = 2.2
18	Feature support	0A	10			RGB display, Preferred Timming mode
19	Red/Green low bits	<b>92</b>	<b>146</b>		-	<b>Red / Green Low Bits</b>
1A	Blue/White low bits	<b>90</b>	<b>144</b>		-	<b>Blue / White Low Bits</b>
1B	Red x high bits	<b>97</b>	<b>151</b>	<b>606</b>	0.592	<b>Red (x) = 10010111 (0.592)</b>
1C	Red y high bits	<b>59</b>	<b>89</b>	<b>357</b>	0.349	<b>Red (y) = 01011001 (0.349)</b>
1D	Green x high bits	<b>55</b>	<b>85</b>	<b>340</b>	0.333	<b>Green (x) = 01010101 (0.333)</b>
1E	Green y high bits	<b>91</b>	<b>145</b>	<b>582</b>	0.569	<b>Green (y) = 10010001 (0.569)</b>
1F	Blue x high bits	<b>28</b>	<b>40</b>	<b>162</b>	0.159	<b>Blue (x) = 00101000 (0.159)</b>
20	BLue y high bits	<b>20</b>	<b>32</b>	<b>129</b>	0.126	<b>Blue (y) = 00100000 (0.126)</b>
21	White x high bits	<b>50</b>	<b>80</b>	<b>320</b>	0.313	<b>White (x) = 01010000 (0.313)</b>
22	White y high bits	<b>54</b>	<b>84</b>	<b>336</b>	0.329	<b>White (y) = 01010100 (0.329)</b>

Address (HEX)	Function	Hex	Dec	crc	Input values.	Notes
23	Established timing 1	00	0		-	
24	Established timing 2	00	0		-	
25	Established timing 3	00	0		-	
26	Standard timing #1	01	1			Not Used
27		01	1			
28	Standard timing #2	01	1			Not Used
29		01	1			
2A	Standard timing #3	01	1			Not Used
2B		01	1			
2C	Standard timing #4	01	1			Not Used
2D		01	1			
2E	Standard timing #5	01	1			Not Used
2F		01	1			
30	Standard timing #6	01	1			Not Used
31		01	1			
32	Standard timing #7	01	1			Not Used
33		01	1			
34	Standard timing #8	01	1			Not Used
35		01	1			
36	Detailed timing/monit or descriptor #1	<b>04</b>	<b>4</b>		<b>71.72</b>	<b>71.72MHz Main clock</b>
37		<b>1C</b>	<b>28</b>			
38		56	86		1366	Hor Active = 1366
39		<b>93</b>	<b>147</b>		<b>147</b>	<b>Hor Blanking = 147</b>
3A		50	80		-	4 bits of Hor. Active + 4 bits of Hor. Blanking
3B		00	0		768	Ver Active = 768
3C		<b>16</b>	<b>22</b>		<b>22</b>	<b>Ver Blanking = 22</b>
3D		30	48		-	4 bits of Ver. Active + 4 bits of Ver. Blanking
3E		30	48		48	Hor Sync Offset = 48
3F		20	32		32	H Sync Pulse Width = 32
40		36	54		3	V sync Offset = 3 line
41		00	0		6	V Sync Pulse width : 6 line
42		25	37		293	Horizontal Image Size = 293 mm (Low 8 bits)
43		A5	165		165	Vertical Image Size = 165 mm (Low 8 bits)
44		10	16		-	4 bits of Hor Image Size + 4 bits of Ver Image Size
45		00	0		0	Hor Border (pixels)
46	00	0		0	Vertical Border (Lines)	
47	1A	26			Refer to right table	

Address (HEX)	Function	Hex	Dec	crc	Input values.	Notes
48	Detailed timing/monit or descriptor #2	<b>D6</b>	<b>214</b>		<b>48.22</b>	<b>48.22MHz Main clock</b>
49		<b>12</b>	<b>18</b>			
4A		56	86		1366	Hor Active = 1366
4B		<b>A0</b>	<b>160</b>		<b>160</b>	<b>Hor Blanking = 160</b>
4C		50	80		-	4 bits of Hor. Active + 4 bits of Hor. Blanking
4D		00	0		768	Ver Active = 768
4E		<b>16</b>	<b>22</b>		<b>22</b>	<b>Ver Blanking = 22</b>
4F		30	48		-	4 bits of Ver. Active + 4 bits of Ver. Blanking
50		30	48		48	Hor Sync Offset = 48
51		20	32		32	H Sync Pulse Width = 32
52		36	54		3	V sync Offset = 3 line
53		00	0		6	V Sync Pulse width : 6 line
54		25	37		293	Horizontal Image Size = 293 mm (Low 8 bits)
55		A5	165		165	Vertical Image Size = 165 mm (Low 8 bits)
56		10	16		-	4 bits of Hor Image Size + 4 bits of Ver Image Size
57		00	0		0	Hor Border (pixels)
58		00	0		0	Vertical Border (Lines)
59	1A	26				
5A	Detailed timing/monitor descriptor #3	00	0			ASCII Data Sting Tag
5B		00	0			
5C		00	0			
5D		FE	254			
5E		00	0			
5F		<b>46</b>	<b>70</b>		<b>F</b>	D/PN: F9RHP
60		<b>39</b>	<b>57</b>		<b>9</b>	
61		<b>52</b>	<b>82</b>		<b>R</b>	
62		<b>48</b>	<b>72</b>		<b>H</b>	<b>EDID:A00</b>
63		<b>50</b>	<b>80</b>		<b>P</b>	
64		<b>80</b>	<b>128</b>		<b>10000000</b>	BOE PN
65		48	72		<b>H</b>	
66		42	66		<b>B</b>	
67	31	49		<b>1</b>		
68	33	51		<b>3</b>		
69	32	50		<b>2</b>		
6A	30	48		<b>0</b>		
6B	<b>31</b>	<b>49</b>		<b>1</b>		



<b>AMELIN</b>	<b>PRODUCT GROUP</b>	REV	ISSUE DATE
	TFT- LCD PRODUCT	P0	
SPEC. NUMBER	SPEC. TITLE HB133WX1-201 Preliminary Product Specification		PAGE 33 OF 33

Address (HEX)	Function	Hex	Dec	crc	Input values.	Notes
6C	Detailed timing/monitor descriptor #4	00	0			Product Name Tag (ASCII)
6D		00	0			
6E		00	0			
6F		00	0			
70		00	0			
71		<b>00</b>	<b>0</b>		<b>00000000</b>	<b>6-bit Color Depth &amp; no FRC</b>
72		<b>41</b>	<b>65</b>		<b>01000001</b>	<b>WLED &amp; singal light bar &amp; one light bar</b>
73		<b>11</b>	<b>17</b>		<b>00010001</b>	<b>Frame rate 40Hz~65Hz</b>
74		<b>94</b>	<b>148</b>		10010100	Light Controller:PWM & Max. Luminance 200
75		<b>00</b>	<b>0</b>		<b>00000000</b>	<b>Front Surface:Anti-Glare&amp; RGB v-stripe</b>
76		<b>00</b>	<b>0</b>		00010000	with DBC
77		<b>00</b>	<b>0</b>		<b>00000000</b>	<b>no Motion Blur &amp; no Active Gamma</b>
78		<b>00</b>	<b>0</b>		<b>00000000</b>	<b>no Wireless Enhancement &amp; no In-Cell Scanner</b>
79		<b>09</b>	<b>9</b>		<b>00001001</b>	1 Lane edp1.2
7A		<b>01</b>	<b>1</b>		<b>00000001</b>	<b>Built-In Self Test</b>
7B		0A	10			
7C	20	32				
7D	20	32				
7E	Extension flag	00	0			
7F	Checksum	35	35	53	-	