

深圳市阿美林电子科技有限公司  
Shenzhen Amelin Electronic Technology Co. Ltd.

# LCD MODULE SPECIFICATION

Customer:

P/N:

Model Name:AML-B16C15012Q

Version: V00

Date: 2016-09-03

For Customer's Acceptance

Approved by	Comment

DESIGN	CHECK	REVIEW

深圳市阿美林电子科技有限公司  
Shenzhen Amelin Electronic Technology Co. Ltd.

CONTENTS:

ITEM	CONTENTS
1	VERSION HISTORY
2	GENERAL INFORMATION
3	ABSOLUTE MAXIMUM RATINGS
4	ELECTRICAL CHARACTERISTICS
5	TIMING OF POWER SUPPLY
6	BACKLIGHT CHARACTERISTICS
7	EXTERNAL DIMENSIONS
8	INTERFACE SIGNALS
9	ELECTRO-OPTICAL CHARACTERISTICS
10	RELIABILITY TEST
11	Quality level
12	TOUCH PANEL CHARACTERISTICS
13	PRECAUTINGS FOR USE OF LCD MODULES

深圳市阿美林电子科技有限公司  
Shenzhen Amelin Electronic Technology Co. Ltd.

 1 VERSION HISTORY

SAMPLE VERSION	DATE	DESCRIPTION	REVISED BY
V00	2016-09-03	FIRST DEVELOPED	ZQS

# 深圳市阿美林电子科技有限公司

Shenzhen Amelin Electronic Technology Co. Ltd.

## 2 GENERAL INFORMATION

Item	Contents	Unit
LCD Size	1.54	inch
Driver element	a-Si TFT active matrix	--
Viewing direction	IPS	
Module Size	35.1*31.2*1.42mm	mm
Touch Panel View Area	/	mm
Touch Panel Active Area	/	mm
Panel Active Area	27.74*27.74	mm
Number of Dots	320(RGB)x320	Pixel
Driver IC	ST7796S	--
Colors	262K	--
Weight	TBD	--
Backlight Type	LED	--
Operating Temperature	-20℃~ +70℃	℃
Storage Temperature	-30℃~ +80℃	℃

## 3 ABSOLUTE MAXIMUM RATINGS

Parameter	Symbol	Min	Max	Unit
Power Supply voltage 1	VCC 2.8	-0.3	+3.6	V
Power Supply voltage 2	VIO1V8	-0.3	+3.6	V
Operating temperature	TOP	-10	+60	℃
Storage temperature	TST	-20	+70	℃
Humidity	RH	-	90%(Max60℃)	RH

# 深圳市阿美林电子科技有限公司

Shenzhen Amelin Electronic Technology Co. Ltd.

## 4 ELECTRICAL CHARACTERISTICS

### DC CHARACTERISTICS

Parameter	Symbol	Min	Typ	Max	Unit
Supply voltage for analog	VCC 2.8	2.6	2.8	3.3	V
Supply voltage for interface I/O	VIO1V8	1.65	—	3.3	V
I/O leakage current	IDD	-	-	TBD	mA
Input voltage 'H'level	VIH	0.7*IOVCC	—	IOVCC	V
Input voltage 'L'level	VIL	0	—	0.3*IOVCC	V
Output voltage 'H'level	VOH	0.8*IOVCC	—	IOVCC	V
Output voltage 'L'level	VOL	0	—	0.2*IOVCC	V

## 5 TIMING OF POWER SUPPLY

PLEASE REFER TO THE DRIVER IC SPECIFICATION.

## 6 BACKLIGHT CHARACTERISTICS

Item	Symbol	Min	Typ	Max	Unit	Condition
Forward voltage	Vf	3.0	3.2	3.4	V	If=60 mA
Luminance	LV	6000	6500	—	cd/m <sup>2</sup>	
Number of LED	-	3			Piece	-
Connection mode	p	3 并			-	-



**深圳市阿美林电子科技有限公司**  
**Shenzhen Amelin Electronic Technology Co. Ltd.**

**8**  **Interface Signal**

Pin No.	Symbol	Description
1	LEDA	LED backlight anode.
2	LEDK	LED backlight cathode.
3	VCC 2.8	Power supply for the analog power.
4	RESET	Reset signal(low active)
5	NC	NC
6	NC	NC
7	NC	NC
8	VDD1.8V	Power supply for the logic power and I/O circuit.
9	GND	Power ground
10	DATA0_P	MIPI-DSI data lane 0 positive input pin.
11	TE	Tearing Effect Output Pin.
12	DATA0_N	MIPI-DSI data lane 0 negative input pin.
13	NC	NC
14	GND	Power ground
15	GND	Power ground
16	CLK_P	MIPI-DSI clock Lane positive input pin.
17	NC	NC
18	CLK_N	MIPI-DSI clock Lane negative input pin.
19	NC	NC
20	GND	Power ground

### 9. ELECTRO-OPTICAL CHARACTERISTICS

Item	Symbol	Condition	Min	Typ	Max	Unit	Remark
Transmittance (w/o DBEF)	T%	$\theta=0^\circ$ $T_a=25^\circ\text{C}$	-	3.3	-	%	
Contrast ratio	Cr		500	800	-	-	3
Response time	Ton+Toff		-	30	40	ms	4
Surface Luminance	LV		-		-	cd/m <sup>2</sup>	2
Viewing angle range	$\theta$	$=90^\circ$		85	-	deg	5
		$=270^\circ$		85	-	deg	
		$=0^\circ$		85	-	deg	
		$=180^\circ$		85	-	deg	
CIE(x,y) chromaticity	Red	x	$\theta=0^\circ$ $T_a=25^\circ\text{C}$	0.650	0.670	0.690	6
		y		0.332	0.352	0.372	
	Green	x		0.317	0.337	0.357	
		y		0.575	0.595	0.615	
	Blue	x		0.139	0.159	0.179	
		y		0.132	0.152	0.172	
	White	x		0.275	0.295	0.315	
		y		0.285	0.305	0.325	

Note 1. Ambient condition:  $25^\circ\text{C}\pm 2^\circ\text{C}$ ,  $60\pm 10\%\text{RH}$ , under 10 Lux in the darkroom.

Note 2. Measure device: BM-7A (TOPCON), viewing cone=  $1^\circ$ ,  $I_L=40\text{mA}$ .

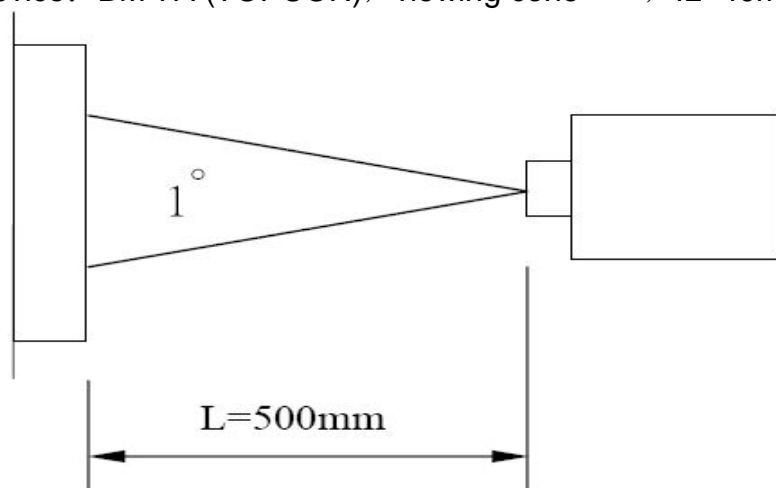



# 深圳市阿美林电子科技有限公司

## Shenzhen Amelin Electronic Technology Co. Ltd.

Note 3. Definition of Contrast Ratio:

$$CR = \text{White Luminance (ON)} / \text{Black Luminance (OFF)}$$

Note 4. Definition of response time: The response time is defined as the time interval between the 10% and 90% amplitudes.

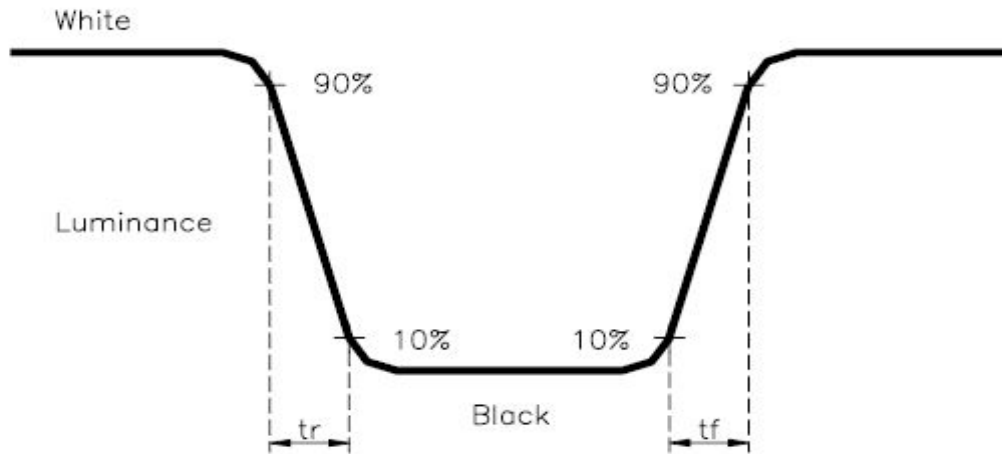

Note 5. Definition of view angle( $\theta$ ,  $\psi$ ):

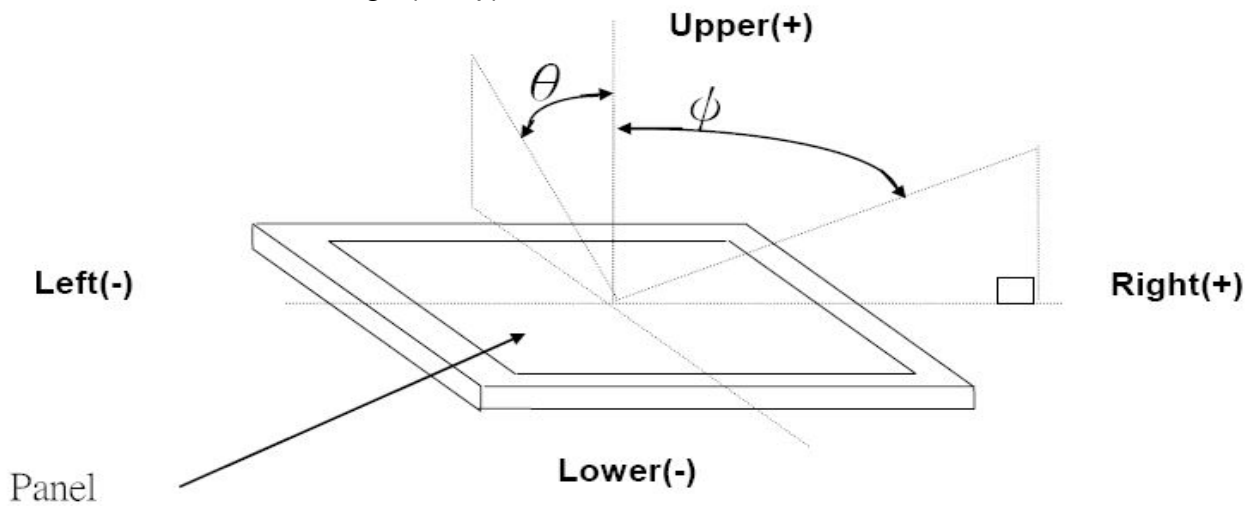

Note 6. Light source: C light.

# 深圳市阿美林电子科技有限公司

Shenzhen Amelin Electronic Technology Co. Ltd.

## 10. RELIABILITY TEST

Reliability test conditions ( Polarizer characteristics null )

No.	Test Items	Test Condition	Remarks
1	High Temperature Storage	T = 60°C for 72hr	Module (Without Contamination)
2	Low Temperature Storage	T = -20°C for 72hr	
3	High Temperature Operating	T = 60°C for 72hr	
4	Low Temperature Operating	T = -10°C for 72hr (But no condensation of dew)	
5	High Temp. and High Humidity Operating	T = 50°C /90% for 72hr (But no condensation dew)	
6	Thermal Shock	-10±2°C~25~60±2°C×10cycles (30min.) (5min.) (30min.)	
7	Packing Shock	1corner, 3edge, 6face / 76cmDrop	Packing
8	Packing Vibration	Random 1.06Grms XYZ 30min for each direction	

※ 1) No.1~ No.6 : No guarantee for panel, only for module with the above test conditions.

※2) No.7~ No.8 : Refer to 7-1) Packing Ass'y on page 14.

### Result Evaluation Criteria

TFT- LCD Panel should be at room temperature for 4hours when the display quality test is over.

There should be no particular change which might affect the practical display function and the display quality test should be conducted under normal operating condition.

## 11. Quality level

### Outgoing Quality Standard.

1 Sample plan

Sampling plan according to GB/T2828.1-2003/ISO 2859-1: 1999 and ANSI/ASQC

Z1.4-1993,

normal level 2 and based on:

Major defect: AQL 0.65

Minor defect: AQL 1.0

2. Inspection condition

Viewing distance for cosmetic inspection is about 30cm with bare eyes, and under an environment

of 20~40W light intensity, all directions for inspecting the sample should be within 45° against perpendicular line.

3. Definition of inspection zone in LCD.

# 深圳市阿美林电子科技有限公司

## Shenzhen Amelin Electronic Technology Co. Ltd.

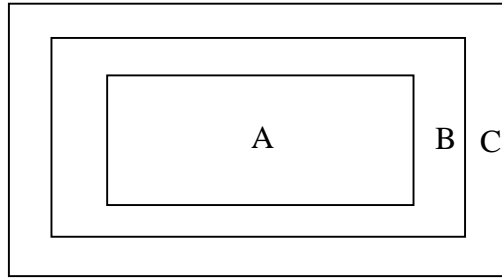

Zone A: character/Digit area

Zone B: viewing area except Zone A (Zone A + Zone B=minimum Viewing area)

Zone C: Outside viewing area (invisible area after assembly in customer's product)

Fig.1 Inspection zones in an LCD.

Note: As a general rule, visual defects in Zone C are permissible, when it is no trouble for quality and assembly of customer's product.

### 4. Standards of inspection items

#### 4.1 Major Defect

Item No	Items to be inspected	Inspection Standard	Classification of defects
4.1.1	All functional defects	1.No display	Major
		2.Display abnormally	
		3.Missing vertical, horizontal segment	
		4.Short circuit	
		5. Back-light no lighting, flickering and abnormal lighting.	
4.1.2	Missing	Missing component	
4.1.3	Outline dimension	Overall outline dimension beyond the drawing is not allowed.	
4.1.4	linearity	No more than 1.5%	

#### 4.2 Cosmetic Defect

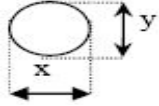
Item No	Items to be inspected	Inspection Standard	Classification of defects								
4.21	Clear Spots Black and white Spot defect Pinhole, Foreign Particle, polarizer Dirt	For dark/white spot, size $\Phi$ is defined as $\Phi = \frac{x + y}{2}$ 	Minor								
		1									
		<table border="1" style="width: 100%; text-align: center;"> <tr> <td style="width: 33%;">Zone</td> <td colspan="3">Acceptable Qty</td> </tr> <tr> <td>Size(mm)</td> <td>A</td> <td>B</td> <td>C</td> </tr> </table>		Zone	Acceptable Qty			Size(mm)	A	B	C
		Zone		Acceptable Qty							
Size(mm)	A	B	C								
$\Phi \leq 0.15$	Ignore		Ignore								

# 深圳市阿美林电子科技有限公司

Shenzhen Amelin Electronic Technology Co. Ltd.

		$0.15 < \Phi \leq 0.20$	2				
		$0.20 < \Phi \leq 0.25$	1				
		$\Phi > 0.25$	0				
Clear Spots TP Dirt	2						Minor
	Zone Size(mm)	Acceptable Qty					
		A	B	C			
	$\Phi \leq 0.15$	Ignore			Ignore		
	$0.15 < \Phi \leq 0.20$	2					
	$0.20 < \Phi \leq 0.25$	1					
	$\Phi > 0.25$	0					
Dim Spots Circle shaped and dim edged defects	3						Minor
	Zone Size(mm)	Acceptable Qty					
		A	B	C			
	$\Phi \leq 0.2$	Ignore			Ignore		
	$0.20 < \Phi \leq 0.40$	2					
	$0.40 < \Phi \leq 0.60$	1					
	$\Phi > 0.60$	0					

## 4.2 Cosmetic Defect

Item No	Items to be inspected	Inspection Standard					Classification of defects
4.2.2	Line defect Black line, White line, Foreign material on polarizer	Size(mm)		Acceptable Qty			Minor
		L(Length)	W(Width)	Zone			
				A	B	C	
		Ignore	$W \leq 0.05$	Ignore		Ignore	
		$L \leq 5.0$	$0.05 < W \leq 0.08$	2			
			$W > 0.08$	0			
Foreign material on TP film	The line can be seen after mobile phone in the operating condition:					Minor	
	Size(mm)		Acceptable Qty				
	L(Length)	W(Width)	Zone				

# 深圳市阿美林电子科技有限公司

Shenzhen Amelin Electronic Technology Co. Ltd.

				A	B	C				
		Ignore	$W \leq 0.05$	Ignore			Ignore			
		$L \leq 5.0$	$0.05 < W \leq 0.08$	3						
			$W > 0.08$	0						
4.2.3	Dim line defect Polarizer scratch TP film scratch	If the scratch can be seen after mobile phone cover assembling or in the operating condition, judge by the line defect of 4.2.2. If the scratch can be seen only in non-operating condition or some special angle, judge by the following.					Minor			
		Size(mm)			Acceptable Qty					
		L(Length)	W(Width)	Zone				Ignore		
				A	B	C				
		Ignore	$W \leq 0.03$	Ignore						
		$5.0 < L \leq 10.0$	$0.03 < W \leq 0.05$	2						
		$L \leq 5.0$	$0.05 < W \leq 0.08$	1						
	$W > 0.08$	0								
4.2.4	Polarize Air bubble	Air bubbles between glass & polarizer					Minor			
		Size(mm)		Zone				Acceptable Qty		
				A	B	C				
		$\Phi \leq 0.20$		Ignore				Ignore		
		$0.20 < \Phi \leq 0.3$		2						
$\Phi > 0.30$		0								

Item No	Items to be inspected	Inspection Standard			Classification of defects
4.35	Glass defect	(i) Chips on corner A:LCD Glass defect			Minor
					
		X(mm)	Y(mm)	Z(mm)	
		$\leq 3.0$	$\leq 3.0$	Disregard	

# 深圳市阿美林电子科技有限公司

## Shenzhen Amelin Electronic Technology Co. Ltd.

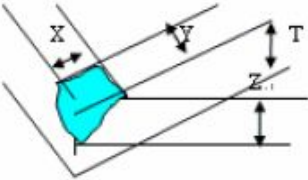
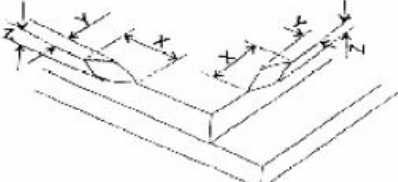
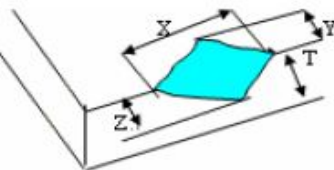
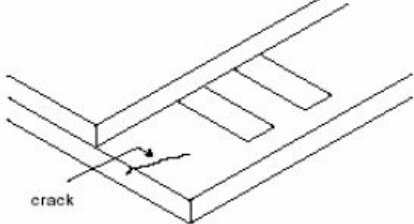
<p>Notes: S=contact pad length                  Chips on the corner of terminal shall not be allowed to extend into the ITO pad or expose perimeter seal.                  B:TP Glass defect</p> 		
X(mm)	Y(mm)	Z(mm)
≤3.0	≤3.0	Disregard
<p>(ii) Usual surface cracks                  A: LCD Glass defect</p> 		
X(mm)	Y(mm)	Z(mm)
≤3.0	< Inner border line of the seal	Disregard
<p>B: TP Glass defect</p> 		
X(mm)	Y(mm)	Z(mm)
≤6.0	< 2.0	Disregard
<p>(iii) Crack                  Cracks tend to break are not allowed.</p> 		

### 12 Touch panel characteristics

Operation life	Tapping durability	>1,000,000 times
	Pen sliding durability	>100,000 times
	Operation force	10-100g
Electric characteristics	Electric characteristics	X: 200~500Ω, Y: 350~800Ω
	Insulation resistance	≥20MΩ (DC25V)
	Linearity	≤1.5%
	Chattering Time	<10ms

### Structure, and Area definition

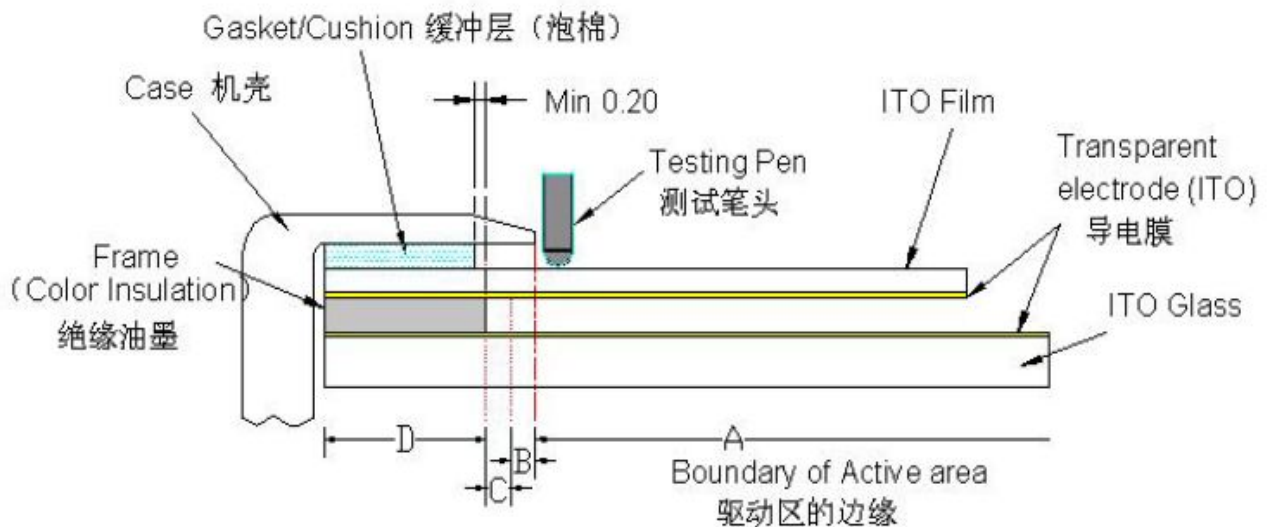

#### Area-(A) : Active area

The area guarantees a touch panel operation with the following characteristics when pressed.

- ( i ) Operation force
- ( ii ) Electric characteristics
- (iii) Tapping durability
- (iv) Pen sliding durability

#### Area-(B) : Operation non-guaranteed area

The area does not guarantee a touch panel operation and its function. When this area is pressed, touch panel shows degradation of its performance and durability such as a pen sliding durability becomes about one-tenth compared with the active area (Area- (A) as guaranteed area) and its operation force requires about double. About 0.5 mm outside from a boundary of the active area corresponds to this area.

#### Area-(C) : Pressing prohibition area

The area forbids pressing because an excessive load is applied to a transparent electrode and a serious damage is given to a touch panel function by pressing. About 0.5mm outside from a boundary of Area-(B)" the operation non-guaranteed area" corresponds to this area.

#### Area-(D) : Non-Active area (Frame)

The area does not activate even if pressed.

(Remark: In order to prevent unusual performance degradation and malfunction of a touch panel, please inspect firstly whether the set case designing and touch panel assembling

method are reasonable or not.)

### **Area-(B)+Area-(C): Sensitive area**

Area-(B) and area-(C) both belong to the sensitive area. This area has a clearance between top and bottom contact side. Great press resulting in transparent electrode cracks, function defect to be exact, will deform surface transparent electrode. Please think about structure of sensitive area and case in order to avoid terminal user to fail to touch this area.

## **13 Precautions for Use of LCD Modules**

### **1. Handling Precautions**

(1) The display panel is made of glass and polarizer. As glass is fragile. It tends to become or chipped during handling especially on the edges. Please avoid dropping or jarring. Do not subject it to a mechanical shock by dropping it or impact.

(2) If the display panel is damaged and the liquid crystal substance leaks out, be sure not to get any in your mouth. If the substance contacts your skin or clothes, wash it off using soap and water.

(3) Do not apply excessive force to the display surface or the adjoining areas since this may cause the color tone to vary. Do not touch the display with bare hands. This will stain the display area and degraded insulation between terminals (some cosmetics are determined to the polarizer).

(4) The polarizer covering the display surface of the LCD module is soft and easily scratched. Handle this polarizer carefully. Do not touch, push or rub the exposed polarizers with anything harder than an HB pencil lead (glass, tweezers, etc.). Do not put or attach anything on the display area to avoid leaving marks on. Condensation on the surface and contact with terminals due to cold will damage, stain or dirty the polarizer. After products are tested at low temperature they must be warmed up in a container before coming in contact with room temperature air.

(5) If the display surface becomes contaminated, breathe on the surface and gently wipe it with a soft dry cloth. If it is heavily contaminated, moisten cloth with one of the following solvents

- Isopropyl alcohol
- Ethyl alcohol

Do not scrub hard to avoid damaging the display surface.

(6) Solvents other than those above-mentioned may damage the polarizer. Especially, do not use the following.

- Water
- Ketone
- Aromatic solvents

Wipe off saliva or water drops immediately, contact with water over a long period of time may cause deformation or color fading. Avoid contacting oil and fats.

(7) Exercise care to minimize corrosion of the electrode. Corrosion of the electrodes is accelerated by water droplets, moisture condensation or a current flow in a high-humidity environment.

(8) Install the LCD Module by using the mounting holes. When mounting the LCD module make sure it is free of twisting, warping and distortion. In particular, do not forcibly pull or bend the IO cable or the backlight cable.



# 深圳市阿美林电子科技有限公司

## Shenzhen Amelin Electronic Technology Co. Ltd.

(9) Do not attempt to disassemble or process the LCD module.

(10) NC terminal should be open. Do not connect anything.

(11) If the logic circuit power is off, do not apply the input signals.

(12) Electro-Static Discharge Control, Since this module uses a CMOS LSI, the same careful attention should be paid to electrostatic discharge as for an ordinary CMOS IC. To prevent destruction of the elements by static electricity, be careful to maintain an optimum work environment.

- Before remove LCM from its packing case or incorporating it into a set, be sure the module and your body have the same electric potential. Be sure to ground the body when handling the LCD modules.

- Tools required for assembling, such as soldering irons, must be properly grounded. make certain the AC power source for the soldering iron does not leak. When using an electric screwdriver to attach LCM, the screwdriver should be of ground potentiality to minimize as much as possible any transmission of electromagnetic waves produced sparks coming from the commutator of the motor.

- To reduce the amount of static electricity generated, do not conduct assembling and other work under dry conditions. To reduce the generation of static electricity be careful that the air in the work is not too dried. A relative humidity of 50%-60% is recommended. As far as possible make the electric potential of your work clothes and that of the work bench the ground potential

- The LCD module is coated with a film to protect the display surface. Exercise care when peeling off this protective film since static electricity may be generated

(13) Since LCM has been assembled and adjusted with a high degree of precision, avoid applying excessive shocks to the module or making any alterations or modifications to it.

- Do not alter, modify or change the shape of the tab on the metal frame.

- Do not make extra holes on the printed circuit board, modify its shape or change the positions of components to be attached.

- Do not damage or modify the pattern writing on the printed circuit board.

- Absolutely do not modify the zebra rubber strip (conductive rubber) or heat seal connector.

- Except for soldering the interface, do not make any alterations or modifications with a soldering iron.

- Do not drop, bend or twist LCM.

### 2. Storage precautions

2.1 When storing the LCD modules, avoid exposure to direct sunlight or to the light of fluorescent lamps.

2.2 The LCD modules should be stored under the storage temperature range. If the LCD modules will be stored for a long time, the recommend condition is:

Temperature :        0°C ~ 40°C        Relatively humidity: ≤80%

2.3 The LCD modules should be stored in the room without acid, alkali and harmful gas.

3 The LCD modules should be no falling and violent shocking during transportation, and also should avoid excessive press, water, damp and sunshine.

----- END